



PEOPLE'S TELEVISION
P A R A S A B A Y A N

People's Television Network, Inc
Broadcast Complex, Visayas Avenue, Diliman, Quezon City 1100
Telephone No. 3453-1097 /www.ptv.ph

PHILIPPINE BIDDING DOCUMENTS

(PROCUREMENT OF INFRASTRUCTURE PROJECTS)

DESIGN AND BUILD OF A FOUR- LEGGED (4) THREE HUNDRED (300) FEET TV BROADCAST TOWER INCLUDING THE TRANSMITTER BUILDING WITH ROOFDECK AND PERIMETER FENCE FOR PTV DAVAO DEL NORTE OF THE PEOPLE'S TELEVISION NETWORK, INC. ITB No. 2022-0005

Government of the Republic of the Philippines

Sixth Edition
March 2022

TABLE OF CONTENTS

SECTION I. INVITATION TO BID FOR	6
SECTION II. INSTRUCTIONS TO BIDDERS	9
1. Scope of Bid	9
2. Funding Information	9
3. Bidding Requirements.....	9
4. Corrupt, Fraudulent, Collusive, Coercive, and Obstructive Practices	9
5. Eligible Bidders.....	10
6. Origin of Associated Goods	10
7. Subcontracts	10
8. Pre-Bid Conference	10
9. Clarification and Amendment of Bidding Documents.....	10
10. Documents Comprising the Bid: Eligibility and Technical Components.....	11
11. Documents Comprising the Bid: Financial Component	11
12. Alternative Bids	12
13. Bid Prices	12
14. Bid and Payment Currencies.....	12
15. Bid Security.....	12
16. Sealing and Marking of Bids.....	12
17. Deadline for Submission of Bids	14
18. Opening and Preliminary Examination of Bids	14
19. Detailed Evaluation and Comparison of Bids.....	14
20. Post Qualification.....	14
21. Signing of the Contract	14
SECTION III. BID DATA SHEET	15
SECTION IV. GENERAL CONDITIONS OF CONTRACT	18
1. Scope of Contract	18
2. Sectional Completion of Works	18
3. Possession of Site.....	18
4. The Contractor's Obligations.....	18
5. Performance Security	18
6. Site Investigation Reports	19
7. Warranty.....	19

8.	Liability of the Contractor.....	19
9.	Termination for Other Causes.....	19
10.	Dayworks	19
11.	Program of Work.....	19
12.	Instructions, Inspections and Audits	20
13.	Advance Payment.....	20
14.	Progress Payments	20
15.	Operating and Maintenance Manuals.....	20
SECTION V. SPECIAL CONDITIONS OF CONTRACT		21
SECTION VI. SPECIFICATIONS.....		22
SECTION VII. DRAWINGS		36
SECTION IX. CHECKLIST OF TECHNICAL AND FINANCIAL DOCUMENTS		49
<i>SECTION X. FORMS</i>		51

Glossary of Terms, Abbreviations, and Acronyms

ABC – Approved Budget for the Contract.

ARCC – Allowable Range of Contract Cost.

BAC – Bids and Awards Committee.

Bid – A signed offer or proposal to undertake a contract submitted by a bidder in response to and in consonance with the requirements of the bidding documents. Also referred to as *Proposal* and *Tender*. (2016 revised IRR, Section 5[c])

Bidder – Refers to a contractor, manufacturer, supplier, distributor and/or consultant who submits a bid in response to the requirements of the Bidding Documents. (2016 revised IRR, Section 5[d])

Bidding Documents – The documents issued by the Procuring Entity as the bases for bids, furnishing all information necessary for a prospective bidder to prepare a bid for the Goods, Infrastructure Projects, and/or Consulting Services required by the Procuring Entity. (2016 revised IRR, Section 5[e])

BIR – Bureau of Internal Revenue.

BSP – Bangko Sentral ng Pilipinas.

CDA – Cooperative Development Authority.

Consulting Services – Refer to services for Infrastructure Projects and other types of projects or activities of the GOP requiring adequate external technical and professional expertise that are beyond the capability and/or capacity of the GOP to undertake such as, but not limited to: (i) advisory and review services; (ii) pre-investment or feasibility studies; (iii) design; (iv) construction supervision; (v) management and related services; and (vi) other technical services or special studies. (2016 revised IRR, Section 5[i])

Contract – Refers to the agreement entered into between the Procuring Entity and the Supplier or Manufacturer or Distributor or Service Provider for procurement of Goods and Services; Contractor for Procurement of Infrastructure Projects; or Consultant or Consulting Firm for Procurement of Consulting Services; as the case may be, as recorded in the Contract Form signed by the parties, including all attachments and appendices thereto and all documents incorporated by reference therein.

Contractor – is a natural or juridical entity whose proposal was accepted by the Procuring Entity and to whom the Contract to execute the Work was awarded. Contractor as used in these Bidding Documents may likewise refer to a supplier, distributor, manufacturer, or consultant.

CPI – Consumer Price Index.

DOLE – Department of Labor and Employment.

DTI – Department of Trade and Industry.

Foreign-funded Procurement or Foreign-Assisted Project – Refers to procurement whose funding source is from a foreign government, foreign or international financing institution as specified in the Treaty or International or Executive Agreement. (2016 revised IRR, Section 5[b]).

GFI – Government Financial Institution.

GOCC – Government-owned and/or –controlled corporation.

Goods – Refer to all items, supplies, materials and general support services, except Consulting Services and Infrastructure Projects, which may be needed in the transaction of public businesses or in the pursuit of any government undertaking, project or activity, whether in the nature of equipment, furniture, stationery, materials for construction, or personal property of any kind, including non-personal or contractual services such as the repair and maintenance of equipment and furniture, as well as trucking, hauling, janitorial, security, and related or analogous services, as well as procurement of materials and supplies provided by the Procuring Entity for such services. The term “related” or “analogous services” shall include, but is not limited to, lease or purchase of office space, media advertisements, health maintenance services, and other services essential to the operation of the Procuring Entity. (2016 revised IRR, Section 5[r])

GOP – Government of the Philippines.

Infrastructure Projects – Include the construction, improvement, rehabilitation, demolition, repair, restoration or maintenance of roads and bridges, railways, airports, seaports, communication facilities, civil works components of information technology projects, irrigation, flood control and drainage, water supply, sanitation, sewerage and solid waste management systems, shore protection, energy/power and electrification facilities, national buildings, school buildings, hospital buildings, and other related construction projects of the government. Also referred to as *civil works or works*. (2016 revised IRR, Section 5[u])

LGUs – Local Government Units.

NFCC – Net Financial Contracting Capacity.

NGA – National Government Agency.

PCAB – Philippine Contractors Accreditation Board.

PhilGEPS - Philippine Government Electronic Procurement System.

Procurement Project – refers to a specific or identified procurement covering goods, infrastructure project or consulting services. A Procurement Project shall be described, detailed, and scheduled in the Project Procurement Management Plan prepared by the agency which shall be consolidated in the procuring entity's Annual Procurement Plan. (GPPB Circular No. 06-2019 dated 17 July 2019)

PSA – Philippine Statistics Authority.

SEC – Securities and Exchange Commission.

SLCC – Single Largest Completed Contract.

UN – United Nations.



PEOPLE'S TELEVISION
P A R A S A B A Y A N

People's Television Network, Inc
Broadcast Complex, Visayas Avenue, Diliman, Quezon City 1100
Telephone No. 3453-1097 /www.ptv.ph

Section I. Invitation to Bid for

Design and Build of a Four-Legged (4) Three Hundred (300) Feet TV Broadcast Tower including the Transmitter Building with Roofdeck and Perimeter Fence for PTV Davao del Norte of the People's Television Network, Inc. ITB No. 2022-0005

1. The *People's Television Network, Inc. (PTNI)*, through the *CAPEX savings* intends to apply the sum of ***Forty-Seven Million Pesos (Php 47,000,000.00)*** being the Approved Budget for the Contract (ABC) to payments under the contract for ***Design and Build of a Four-Legged (4) Three Hundred (300) Feet TV Broadcast Tower including the Transmitter Building with Roofdeck and Perimeter Fence for PTV Davao del Norte of the People's Television Network, Inc., ITB No. 2022-0005***. Bids received in excess of the ABC shall be automatically rejected at bid opening.
2. The *People's Television Network, Inc. (PTNI)* now invites bids for the above Procurement Project. Completion of the Works is required ***One Hundred Fifty (150) Calendar Days upon receipt of Notice to Proceed***. Bidders should have completed a contract similar to the Project. The description of an eligible bidder is contained in the Bidding Documents, particularly, in Section II (Instructions to Bidders).
3. Bidding will be conducted through open competitive bidding procedures using non-discretionary "*pass/fail*" criterion as specified in the 2016 revised Implementing Rules and Regulations (IRR) of Republic Act (RA) No. 9184.
4. Interested bidders may obtain further information from *People's Television Network, Inc. (PTNI)* and inspect the Bidding Documents at the address given below from 9:00 am to 5:00 pm.
5. A complete set of Bidding Documents may be acquired by interested bidders on ***6 March 2022*** from given address and website/s below *and upon payment of the applicable fee for the Bidding Documents, pursuant to the latest Guidelines issued by the GPPB, in the amount of Twenty-Five Thousand Pesos (PHP 25,000.00)*. The Procuring Entity shall allow the bidder to present its proof of payment for the fees *presented in person or through electronic means*.

Interested bidders shall pay through any the following means:

1. Cashier (In Person)
 - Kindly inform the Secretariat though this number/s 0956-738-4512/ 0961-693-8333 upon arrival.
 - Transaction will be done at entrance gate only.

- Cashier is available from Mon-Fri, 9:00 AM - 5:00 PM.

2. PTNI's Bank Account (Land Bank of the Philippines).

- Account Name: PTNI
- Account Number: 3212100497
- Kindly Email the proof of payment at bacsecretariat@ptni.gov.ph after the transaction

6. The ***People's Television Network, Inc. (PTNI)*** will hold a Pre-Bid Conference on ***14 March 2022 at 4:00 PM*** through videoconferencing/webcasting *via Zoom*, which shall be open to prospective bidders.

Meeting ID : 883 2609 4166
Passcode : 2022-0005

7. Bids must be duly received by the BAC Secretariat through manual submission at the office address as indicated below on or before ***28 March 2022 at 4:00 PM***. Late bids shall not be accepted.
8. All bids must be accompanied by a bid security in any of the acceptable forms and in the amount stated in **ITB** Clause 16.
9. Bid opening shall be on ***28 March 2022 at 4:30 PM*** at the given address below and/or through Zoom. Bids will be opened in the presence of the bidders' representatives who choose to attend the activity.

Meeting ID : 894 3179 6972
Passcode : 2022-0005

10. People's Television Network, Inc. (PTNI) Health and Safety Protocols and Additional Guidelines during Procurement Activities:

1. Site Inspection

- The site inspection is scheduled on **March 10-11, 2022** at **Capitol Compound, Mankilam, Tagum City, Davao Del Norte**.
- Please confirm your intent to participate through the BAC Secretariat at 09616938333/09567384512 and bacsecretariat@ptni.gov.ph
- **Engr. Emmanuel Sugang** will serve as PTNI's representative, you may contact them at **+639550520088**
- Interested Bidder shall enforce the following precautionary measures among themselves:
 - Observe physical distancing.
 - Present a COVID-19 vaccination card or any proof of COVID-19 vaccination
 - Wear face mask (at least 3-ply surgical mask, preferably N95 mask) and face shield at all times.
 - Submit duly accomplished Health Declaration form.
 - Follow Health Protocols set by the Local Government Unit (LGU)
- The certificate of Site Inspection will be signed by the PTNI's representative after the activity, which shall be required to include in the bid tender (Technical Component).

2. Pre-Bid Conference
 - PTNI will hold its pre-bid conference on the specified date and time through videoconferencing/webcasting via Zoom.
 - Kindly send a letter of intent with the name of the company representative and his/her contact detail (mobile/telephone number and email address) to participate in the conference.
 3. Opening and Submission of Bids
 - PTNI will still require manual submission of bid.
 - The bidder must submit its bid on time with proper label and sealing.
 - Bidder may have one (1) representative to attend physically during the Bid Opening whose shall enforce the following precautionary measures among themselves:
 - Observe physical distancing.
 - Present a COVID-19 vaccination card or any proof of COVID-19 vaccination
 - Wear face mask (at least 3-ply surgical mask, preferably N95 mask) and face shield at all times.
 - Submit duly accomplished Health Declaration forms and COVID-19 Negative Rapid Antigen Test (AgT) or RT-PCR test results from within the last 48-hours before the date of Opening of Bids.
 - Bidder may also participate virtually and watch the activity through video conferencing via Zoom
11. The *People's Television Network, Inc. (PTNI)* reserves the right to reject any and all bids, declare a failure of bidding, or not award the contract at any time prior to contract award in accordance with Sections 35.6 and 41 of the 2016 revised Implementing Rules and Regulations (IRR) of RA No. 9184, without thereby incurring any liability to the affected bidder or bidders.
12. For further information, please refer to:

BAC Secretariat

People's Television Network, Inc. (PTNI)
3rd Floor, PTNI Broadcast Complex,
Visayas Avenue, Diliman, Quezon City
bacsecretariat@ptni.gov.ph
0956-738-4512 / 0961-693-8333
www.ptni.gov.ph

13. You may visit the following websites:
Bidding Documents: ptni.gov.ph/procurement/
Procurement forms: <https://www.gppb.gov.ph/downloadables.php>

6 March 2022



ATTY. JASON SHAHEER H. SALENDAB
Chairperson, Bids and Awards Committee

Section II. Instructions to Bidders

1. Scope of Bid

The Procuring Entity, *People's Television Network, Inc. (PTNI)* invites Bids for the ***Design and Build of a Four-Legged (4) Three Hundred (300) Feet TV Broadcast Tower including the Transmitter Building with Roofdeck and Perimeter Fence for PTV Davao del Norte of the People's Television Network, Inc.***, with Project Identification Number ***ITB No. 2022-0005***.

The Procurement Project (referred to herein as "Project") is for the construction of Works, as described in Section VI (Specifications).

2. Funding Information

2.1. The GOP through the source of funding as indicated below for ***CAPEX Savings*** in the amount of ***Forty-Seven Million Pesos (Php 47,000,000.00)***.

2.2. The source of funding is the **General Appropriations Act**

3. Bidding Requirements

The Bidding for the Project shall be governed by all the provisions of RA No. 9184 and its 2016 revised IRR, including its Generic Procurement Manual and associated policies, rules and regulations as the primary source thereof, while the herein clauses shall serve as the secondary source thereof.

Any amendments made to the IRR and other GPPB issuances shall be applicable only to the ongoing posting, advertisement, or invitation to bid by the BAC through the issuance of a supplemental or bid bulletin.

The Bidder, by the act of submitting its Bid, shall be deemed to have inspected the site, determined the general characteristics of the contracted Works and the conditions for this Project, such as the location and the nature of the work; (b) climatic conditions; (c) transportation facilities; (c) nature and condition of the terrain, geological conditions at the site communication facilities, requirements, location and availability of construction aggregates and other materials, labor, water, electric power and access roads; and (d) other factors that may affect the cost, duration and execution or implementation of the contract, project, or work and examine all instructions, forms, terms, and project requirements in the Bidding Documents.

4. Corrupt, Fraudulent, Collusive, Coercive, and Obstructive Practices

The Procuring Entity, as well as the Bidders and Contractors, shall observe the highest standard of ethics during the procurement and execution of the contract. They or through an agent shall not engage in corrupt, fraudulent, collusive, coercive, and obstructive practices defined under Annex "I" of the 2016 revised IRR of RA No. 9184 or other integrity violations in competing for the Project.

5. Eligible Bidders

- 5.1. Only Bids of Bidders found to be legally, technically, and financially capable will be evaluated.
- 5.2. The Bidder must have an experience of having completed a Single Largest Completed Contract (SLCC) that is similar to this Project, equivalent to at least fifty percent (50%) of the ABC adjusted, if necessary, by the Bidder to current prices using the PSA's CPI, except under conditions provided for in Section 23.4.2.4 of the 2016 revised IRR of RA No. 9184.

A contract is considered to be "similar" to the contract to be bid if it has the major categories of work stated in the **BDS**.
- 5.3. For Foreign-funded Procurement, the Procuring Entity and the foreign government/foreign or international financing institution may agree on another track record requirement, as specified in the Bidding Document prepared for this purpose.
- 5.4. The Bidders shall comply with the eligibility criteria under Section 23.4.2 of the 2016 IRR of RA No. 9184.

6. Origin of Associated Goods

There is no restriction on the origin of Goods other than those prohibited by a decision of the UN Security Council taken under Chapter VII of the Charter of the UN.

7. Subcontracts

- 7.1. The Bidder may subcontract portions of the Project to the extent allowed by the Procuring Entity as stated herein, but in no case more than fifty percent (50%) of the Project.

The Procuring Entity has prescribed that Subcontracting is not allowed.

- 7.1. Subcontracting of any portion of the Project does not relieve the Contractor of any liability or obligation under the Contract. The Supplier will be responsible for the acts, defaults, and negligence of any subcontractor, its agents, servants, or workmen as fully as if these were the Contractor's own acts, defaults, or negligence, or those of its agents, servants, or workmen.

8. Pre-Bid Conference

The Procuring Entity will hold a pre-bid conference for this Project on the specified date and time through videoconferencing/webcasting via Zoom as indicated in paragraph 6 of the **IB**.

9. Clarification and Amendment of Bidding Documents

Prospective bidders may request for clarification on and/or interpretation of any part of the Bidding Documents. Such requests must be in writing and received by the Procuring Entity, either at its given address or through electronic mail indicated in the **IB**, at least ten (10) calendar days before the deadline set for the submission and receipt of Bids.

10. Documents Comprising the Bid: Eligibility and Technical Components

- 10.1. The first envelope shall contain the eligibility and technical documents of the Bid as specified in **Section IX. Checklist of Technical and Financial Documents**.
- 10.2. If the eligibility requirements or statements, the bids, and all other documents for submission to the BAC are in foreign language other than English, it must be accompanied by a translation in English, which shall be authenticated by the appropriate Philippine foreign service establishment, post, or the equivalent office having jurisdiction over the foreign bidder's affairs in the Philippines. For Contracting Parties to the Apostille Convention, only the translated documents shall be authenticated through an apostille pursuant to GPPB Resolution No. 13-2019 dated 23 May 2019. The English translation shall govern, for purposes of interpretation of the bid.
- 10.3. A valid PCAB License is required, and in case of joint ventures, a valid special PCAB License, and registration for the type and cost of the contract for this Project. Any additional type of Contractor license or permit shall be indicated in the **BDS**.
- 10.4. A List of Contractor's key personnel (e.g., Project Manager, Project Engineers, Materials Engineers, and Foremen) assigned to the contract to be bid, with their complete qualification and experience data shall be provided. These key personnel must meet the required minimum years of experience set in the **BDS**.
- 10.5. A List of Contractor's major equipment units, which are owned, leased, and/or under purchase agreements, supported by proof of ownership, certification of availability of equipment from the equipment lessor/vendor for the duration of the project, as the case may be, must meet the minimum requirements for the contract set in the **BDS**.

11. Documents Comprising the Bid: Financial Component

- 11.1. The second bid envelope shall contain the financial documents for the Bid as specified in **Section IX. Checklist of Technical and Financial Documents**.
- 11.2. Any bid exceeding the ABC indicated in paragraph 1 of the **IB** shall not be accepted.

- 11.3. For Foreign-funded procurement, a ceiling may be applied to bid prices provided the conditions are met under Section 31.2 of the 2016 revised IRR of RA No. 9184.

12. Alternative Bids

Bidders shall submit offers that comply with the requirements of the Bidding Documents, including the basic technical design as indicated in the drawings and specifications. Unless there is a value engineering clause in the **BDS**, alternative Bids shall not be accepted.

13. Bid Prices

All bid prices for the given scope of work in the Project as awarded shall be considered as fixed prices, and therefore not subject to price escalation during contract implementation, except under extraordinary circumstances as determined by the NEDA and approved by the GPPB pursuant to the revised Guidelines for Contract Price Escalation guidelines.

14. Bid and Payment Currencies

14.1. Bid prices may be quoted in the local currency or tradeable currency accepted by the BSP at the discretion of the Bidder. However, for purposes of bid evaluation, Bids denominated in foreign currencies shall be converted to Philippine currency based on the exchange rate as published in the BSP reference rate bulletin on the day of the bid opening.

14.2. *Payment of the contract price shall be made in Philippine Pesos.*

15. Bid Security

15.1. The Bidder shall submit a Bid Securing Declaration or any form of Bid Security in the amount indicated in the **BDS**, which shall be not less than the percentage of the ABC in accordance with the schedule in the **BDS**.

15.2. The Bid and bid security shall be valid until One Hundred Twenty (120) Calendar Days from the date of the Opening of Bids. Any bid not accompanied by an acceptable bid security shall be rejected by the Procuring Entity as non-responsive.

16. Sealing and Marking of Bids

Each Bidder shall submit one (1) original, additional one (1) copy and electronic copy in USB Flash Drive (Real PDF, Doc or Docx format) of the first and second components of its Bid.

The Procuring Entity may request additional hard copies and/or electronic copies of the Bid. However, failure of the Bidders to comply with the said request shall not be a ground for disqualification.

If the Procuring Entity allows the submission of bids through online submission to the given website or any other electronic means, the Bidder shall submit an electronic copy of its Bid, which must be digitally signed. An electronic copy that cannot be opened or is corrupted shall be considered non-responsive and, thus, automatically disqualified.

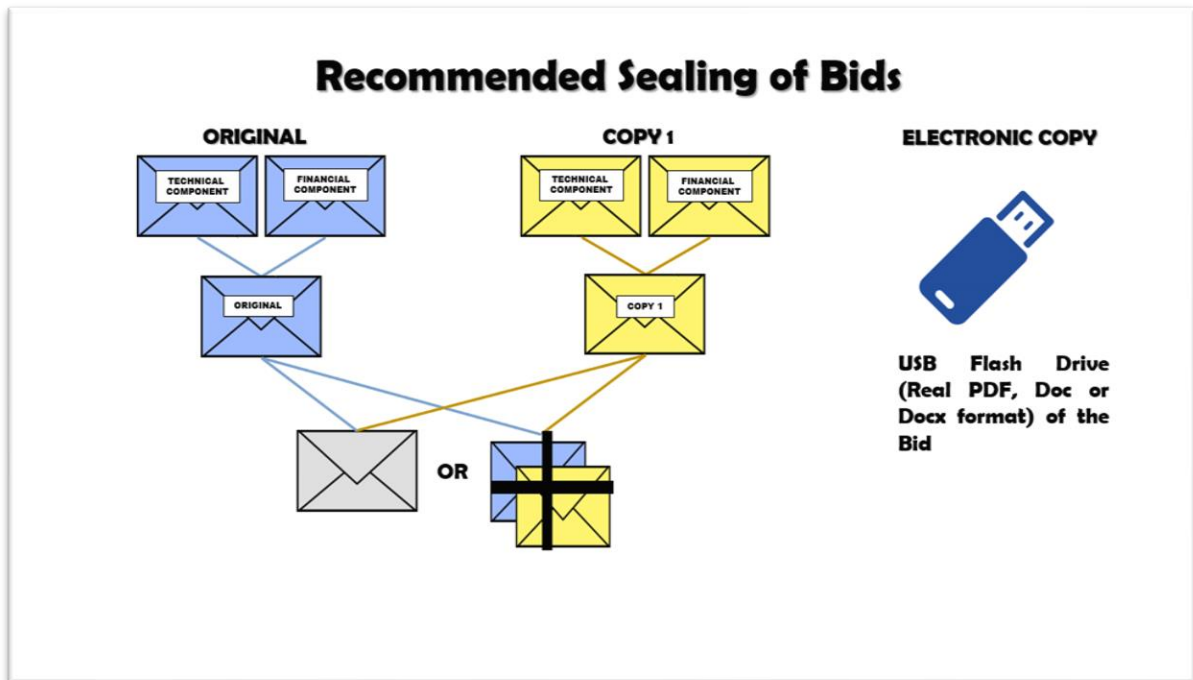

Recommended Marking of Bids

ATTY. JASON SHAHEER H. SALENDAB
 Chairperson
 Bids and Awards Committee
 PTNI Broadcast Complex,
 Visayas Avenue, Diliman, Quezon City

Bid for
 ITB No. _____
 Project Title _____

Submitted By
 Bidder's company name _____
 Bidder's contact details _____

"DO NOT OPEN BEFORE (the date and time of opening of bids)"

17. Deadline for Submission of Bids

The Bidders shall submit on the specified date and time and either at its physical address or through online submission as indicated in paragraph 7 of the **IB**.

18. Opening and Preliminary Examination of Bids

18.1. The BAC shall open the Bids in public at the time, on the date, and at the place specified in paragraph 9 of the **IB**. The Bidders' representatives who are present shall sign a register evidencing their attendance. In case videoconferencing, webcasting or other similar technologies will be used, attendance of participants shall likewise be recorded by the BAC Secretariat.

In case the Bids cannot be opened as scheduled due to justifiable reasons, the rescheduling requirements under Section 29 of the 2016 revised IRR of RA No. 9184 shall prevail.

18.2. The preliminary examination of Bids shall be governed by Section 30 of the 2016 revised IRR of RA No. 9184.

19. Detailed Evaluation and Comparison of Bids

19.1. The Procuring Entity's BAC shall immediately conduct a detailed evaluation of all Bids rated "*passed*" using non-discretionary pass/fail criteria. The BAC shall consider the conditions in the evaluation of Bids under Section 32.2 of 2016 revised IRR of RA No. 9184.

19.2. If the Project allows partial bids, all Bids and combinations of Bids as indicated in the **BDS** shall be received by the same deadline and opened and evaluated simultaneously so as to determine the Bid or combination of Bids offering the lowest calculated cost to the Procuring Entity. Bid Security as required by **ITB** Clause 15 shall be submitted for each contract (lot) separately.

19.3. In all cases, the NFCC computation pursuant to Section 23.4.2.6 of the 2016 revised IRR of RA No. 9184 must be sufficient for the total of the ABCs for all the lots participated in by the prospective Bidder.

20. Post Qualification

Within a non-extendible period of five (5) calendar days from receipt by the Bidder of the notice from the BAC that it submitted the Lowest Calculated Bid, the Bidder shall submit its latest income and business tax returns filed and paid through the BIR Electronic Filing and Payment System (eFPS), and other appropriate licenses and permits required by law and stated in the **BDS**.

21. Signing of the Contract

The documents required in Section 37.2 of the 2016 revised IRR of RA No. 9184 shall form part of the Contract. Additional Contract documents are indicated in the **BDS**.

Section III. Bid Data Sheet

ITB Clause													
5.2	<p>For this purpose, contracts similar to the Project refer to contracts which have the same major categories of work, which shall be:</p> <p>Design and Build of a four (4) Legged Broadcast/ Communication Tower and Equipment Building</p>												
7.1	Subcontracting is not allowed.												
10.3	<p>The required PCAB License is at least <i>Category B Size Range Medium A for Buildings</i></p> <p>No additional Contractor license or permit is required aside from PCAB License</p>												
10.4	<p>The key personnel must meet the required minimum years of experience set below:</p> <p><u>Key Personnel</u> <u>General Experience</u> <u>Relevant Experience</u></p> <p><u>DETAILED DESIGN KEY PERSONNEL</u></p> <table border="1" style="width: 100%; border-collapse: collapse;"> <thead> <tr> <th style="text-align: center;">Required Professional</th> <th style="text-align: center;">Minimum Qualification</th> </tr> </thead> <tbody> <tr> <td style="text-align: center;">Structural Engineer</td> <td>must be duly licensed Structural Engineer with at least 10 years of experience in structural design and has undertaken projects with project cost of at least 50% of the ABC; with substantial knowledge in structural and earthquake design of building and broadcast tower structures.</td> </tr> <tr> <td style="text-align: center;">Design Architect</td> <td>must be duly licensed and an active member of Integrated and Accredited Professional Organization of Architects (IAPOA) with at least 10 years of experience in the architectural design of commercial, academic or institutional facilities and corporate buildings, site planning and landscaping.</td> </tr> <tr> <td style="text-align: center;">Professional Electrical Engineer</td> <td>must be duly licensed with at least 10 years of experience in building electrical design, lighting, power distribution, switches and panels and preferably knowledgeable in efficient lighting technologies and energy management.</td> </tr> <tr> <td style="text-align: center;">Professional Mechanical Engineer</td> <td>must be duly licensed with at least 5 years of experience in mechanical design and installations of HVAC and fire protection and suppression systems and preferably knowledgeable in emergent, alternative energy-efficient HVAC technologies.</td> </tr> <tr> <td style="text-align: center;">Professional Electronics Engineer</td> <td>must be duly licensed with at least 5 years of experience in building electronics design, as well as fire detection and alarm systems in buildings.</td> </tr> </tbody> </table>	Required Professional	Minimum Qualification	Structural Engineer	must be duly licensed Structural Engineer with at least 10 years of experience in structural design and has undertaken projects with project cost of at least 50% of the ABC; with substantial knowledge in structural and earthquake design of building and broadcast tower structures.	Design Architect	must be duly licensed and an active member of Integrated and Accredited Professional Organization of Architects (IAPOA) with at least 10 years of experience in the architectural design of commercial, academic or institutional facilities and corporate buildings, site planning and landscaping.	Professional Electrical Engineer	must be duly licensed with at least 10 years of experience in building electrical design, lighting, power distribution, switches and panels and preferably knowledgeable in efficient lighting technologies and energy management.	Professional Mechanical Engineer	must be duly licensed with at least 5 years of experience in mechanical design and installations of HVAC and fire protection and suppression systems and preferably knowledgeable in emergent, alternative energy-efficient HVAC technologies.	Professional Electronics Engineer	must be duly licensed with at least 5 years of experience in building electronics design, as well as fire detection and alarm systems in buildings.
Required Professional	Minimum Qualification												
Structural Engineer	must be duly licensed Structural Engineer with at least 10 years of experience in structural design and has undertaken projects with project cost of at least 50% of the ABC; with substantial knowledge in structural and earthquake design of building and broadcast tower structures.												
Design Architect	must be duly licensed and an active member of Integrated and Accredited Professional Organization of Architects (IAPOA) with at least 10 years of experience in the architectural design of commercial, academic or institutional facilities and corporate buildings, site planning and landscaping.												
Professional Electrical Engineer	must be duly licensed with at least 10 years of experience in building electrical design, lighting, power distribution, switches and panels and preferably knowledgeable in efficient lighting technologies and energy management.												
Professional Mechanical Engineer	must be duly licensed with at least 5 years of experience in mechanical design and installations of HVAC and fire protection and suppression systems and preferably knowledgeable in emergent, alternative energy-efficient HVAC technologies.												
Professional Electronics Engineer	must be duly licensed with at least 5 years of experience in building electronics design, as well as fire detection and alarm systems in buildings.												

Sanitary Engineer/ Registered Master Plumber	must be duly licensed with at least 5 years of experience in the design of building water supply and distribution systems, plumbing and sanitary systems and preferably knowledgeable in and emergent, alternative effluent collection and treatment systems.
Geotechnical Engineer	must be duly licensed Civil Engineer with a post graduate degree in Geotechnical Engineering or PICE Specialization with at least 5 years of experience in geotechnical evaluation.
Cost/ Quantity/ Specifications Engineer	must be duly licensed Civil Engineer with at least 5 years of experience in the preparation of technical specifications and detailed analysis of all applicable unit prices.

CONSTRUCTION KEY PERSONNEL

Required Professional	Minimum Qualification
Project Manager/ Structural Engineer	a duly licensed Structural Engineer with at least ten (10) years of experience in Structural Engineering and member of the Association of Structural Engineers of the Philippines (ASEP) with substantial knowledge in the structural design of broadcast towers in accordance with the National Structural Code of the Philippines, experienced in the direction and administration of activities pertinent to the planning and design of broadcast towers, transmitter buildings and site development.
Project Manager for Construction	a duly licensed Civil Engineer with at least five (5) years of experience in the construction of Broadcast Towers and experienced in the direction and administration of activities pertinent to the retrofitting works of broadcast towers.
Cost/Quantity/ Specs Engineer	with wide experience in the preparation of tender documents and technical specifications, and in the preparation of detailed analysis of all applicable unit prices.
Project Engineer	a duly licensed Civil Engineer and/or an Electronics Engineer with at least three (3) years of experience in the supervision/implementation of building rehabilitation and broadcast tower projects.
Professional Electrical Engineer (PEE),	a duly licensed Professional Electrical Engineer with at least five (5) years of extensive experience in tower electrical design and construction/ retrofitting and has substantial knowledge in the electrical systems design of broadcast tower and tower facilities.
Professional Electronics Engineer (PECE)	a duly licensed Professional Electronics Engineer with at least five (5) years of extensive experience in TV antenna design.

	<table border="1"> <tr> <td>Safety Officer</td> <td>must have undergone the prescribed 40 hours of Construction Safety and Health Training (COSH), duly supported by a Certificate of Completion issued by any DOLE/BWC accredited entity with at least three (3) years of experience in construction of tower projects.</td> </tr> </table>	Safety Officer	must have undergone the prescribed 40 hours of Construction Safety and Health Training (COSH), duly supported by a Certificate of Completion issued by any DOLE/BWC accredited entity with at least three (3) years of experience in construction of tower projects.																
Safety Officer	must have undergone the prescribed 40 hours of Construction Safety and Health Training (COSH), duly supported by a Certificate of Completion issued by any DOLE/BWC accredited entity with at least three (3) years of experience in construction of tower projects.																		
10.5	<p>The minimum major equipment requirements are the following:</p> <table border="1"> <thead> <tr> <th>Equipment</th> <th>Capacity</th> <th>Number of Units</th> </tr> </thead> <tbody> <tr> <td>Bagger Mixer</td> <td>300L</td> <td>2</td> </tr> <tr> <td>Concrete Vibrator</td> <td>2hp</td> <td>2</td> </tr> <tr> <td>Welding Machine</td> <td>200amp</td> <td>2</td> </tr> <tr> <td>Telescopic Boom Crane</td> <td></td> <td>1</td> </tr> <tr> <td>Others</td> <td></td> <td></td> </tr> </tbody> </table>	Equipment	Capacity	Number of Units	Bagger Mixer	300L	2	Concrete Vibrator	2hp	2	Welding Machine	200amp	2	Telescopic Boom Crane		1	Others		
Equipment	Capacity	Number of Units																	
Bagger Mixer	300L	2																	
Concrete Vibrator	2hp	2																	
Welding Machine	200amp	2																	
Telescopic Boom Crane		1																	
Others																			
12	Alternative Bids is not allowed.																		
15.1	<p>The bid security shall be in the form of a Bid Securing Declaration or any of the following forms and amounts:</p> <ol style="list-style-type: none"> The amount of not less than <i>two percent (2%) of ABC</i>, if bid security is in cash, cashier's/manager's check, bank draft/guarantee or irrevocable letter of credit; The amount of not less than <i>five percent (5%) of ABC</i> if bid security is in Surety Bond. 																		
19.2	Partial bids are not allowed																		
20	<p>Latest income and business tax returns filed and paid through the BIR Electronic Filing and Payment System (eFPS)</p> <p>No additional licenses and permits relevant to the Project and the corresponding law is required.</p>																		
21	<p>Additional contract documents relevant to the Project required by existing laws and/or the Procuring Entity to be submitted <i>within Ten (10) calendar Days upon the receipt of Notice of Award:</i></p> <ul style="list-style-type: none"> <i>Organizational Chart for the contract to bid</i> <i>Duly signed Construction Schedule, S-Curve and PERT-CPM Network Diagram;</i> <i>Duly signed Manpower Schedule</i> <i>Duly signed Construction Method in narrative form</i> <i>Construction safety and health program approved by the DOLE</i> <i>Contractor's All Risk Insurance</i> 																		

Section IV. General Conditions of Contract

1. Scope of Contract

This Contract shall include all such items, although not specifically mentioned, that can be reasonably inferred as being required for its completion as if such items were expressly mentioned herein. All the provisions of RA No. 9184 and its 2016 revised IRR, including the Generic Procurement Manual, and associated issuances, constitute the primary source for the terms and conditions of the Contract, and thus, applicable in contract implementation. Herein clauses shall serve as the secondary source for the terms and conditions of the Contract.

This is without prejudice to Sections 74.1 and 74.2 of the 2016 revised IRR of RA No. 9184 allowing the GPPB to amend the IRR, which shall be applied to all procurement activities, the advertisement, posting, or invitation of which were issued after the effectivity of the said amendment.

2. Sectional Completion of Works

If sectional completion is specified in the **Special Conditions of Contract (SCC)**, references in the Conditions of Contract to the Works, the Completion Date, and the Intended Completion Date shall apply to any Section of the Works (other than references to the Completion Date and Intended Completion Date for the whole of the Works).

3. Possession of Site

3.1 The Procuring Entity shall give possession of all or parts of the Site to the Contractor based on the schedule of delivery indicated in the **SCC**, which corresponds to the execution of the Works. If the Contractor suffers delay or incurs cost from failure on the part of the Procuring Entity to give possession in accordance with the terms of this clause, the Procuring Entity's Representative shall give the Contractor a Contract Time Extension and certify such sum as fair to cover the cost incurred, which sum shall be paid by Procuring Entity.

3.2 If possession of a portion is not given by the above date, the Procuring Entity will be deemed to have delayed the start of the relevant activities. The resulting adjustments in contract time to address such delay may be addressed through contract extension provided under Annex "E" of the 2016 revised IRR of RA No. 9184.

4. The Contractor's Obligations

The Contractor shall employ the key personnel named in the Schedule of Key Personnel indicating their designation, in accordance with **ITB** Clause 10.3 and specified in the **BDS**, to carry out the supervision of the Works.

The Procuring Entity will approve any proposed replacement of key personnel only if their relevant qualifications and abilities are equal to or better than those of the personnel listed in the Schedule.

5. Performance Security

- 5.1. Within ten (10) calendar days from receipt of the Notice of Award from the Procuring Entity but in no case later than the signing of the contract by both parties, the successful Bidder shall furnish the performance security in any of the forms prescribed in Section 39 of the 2016 revised IRR.
- 5.2. The Contractor, by entering into the Contract with the Procuring Entity, acknowledges the right of the Procuring Entity to institute action pursuant to RA No. 3688 against any subcontractor be they an individual, firm, partnership, corporation, or association supplying the Contractor with labor, materials and/or equipment for the performance of this Contract.

6. Site Investigation Reports

The Contractor, in preparing the Bid, shall rely on any Site Investigation Reports referred to in the SCC supplemented by any information obtained by the Contractor.

7. Warranty

- 7.1. In case the Contractor fails to undertake the repair works under Section 62.2.2 of the 2016 revised IRR, the Procuring Entity shall forfeit its performance security, subject its property(ies) to attachment or garnishment proceedings, and perpetually disqualify it from participating in any public bidding. All payables of the GOP in his favor shall be offset to recover the costs.
- 7.2. The warranty against Structural Defects/Failures, except that occasioned-on force majeure, shall cover the period from the date of issuance of the Certificate of Final Acceptance by the Procuring Entity. Specific duration of the warranty is found in the SCC.

8. Liability of the Contractor

Subject to additional provisions, if any, set forth in the SCC, the Contractor's liability under this Contract shall be as provided by the laws of the Republic of the Philippines.

If the Contractor is a joint venture, all partners to the joint venture shall be jointly and severally liable to the Procuring Entity.

9. Termination for Other Causes

Contract termination shall be initiated in case it is determined *prima facie* by the Procuring Entity that the Contractor has engaged, before, or during the implementation of the contract, in unlawful deeds and behaviors relative to contract acquisition and implementation, such as, but not limited to corrupt, fraudulent, collusive, coercive, and obstructive practices as stated in ITB Clause 4.

10. Dayworks

Subject to the guidelines on Variation Order in Annex "E" of the 2016 revised IRR of RA No. 9184, and if applicable as indicated in the SCC, the Dayworks rates in the Contractor's Bid shall be used for small additional amounts of work only when the Procuring Entity's Representative has given written instructions in advance for additional work to be paid for in that way.

11. Program of Work

- 11.1. The Contractor shall submit to the Procuring Entity's Representative for approval the said Program of Work showing the general methods, arrangements, order, and timing for all the activities in the Works. The submissions of the Program of Work are indicated in the **SCC**.
- 11.2. The Contractor shall submit to the Procuring Entity's Representative for approval an updated Program of Work at intervals no longer than the period stated in the **SCC**. If the Contractor does not submit an updated Program of Work within this period, the Procuring Entity's Representative may withhold the amount stated in the **SCC** from the next payment certificate and continue to withhold this amount until the next payment after the date on which the overdue Program of Work has been submitted.

12. Instructions, Inspections and Audits

The Contractor shall permit the GOP or the Procuring Entity to inspect the Contractor's accounts and records relating to the performance of the Contractor and to have them audited by auditors of the GOP or the Procuring Entity, as may be required.

13. Advance Payment

The Procuring Entity shall, upon a written request of the Contractor which shall be submitted as a Contract document, make an advance payment to the Contractor in an amount not exceeding fifteen percent (15%) of the total contract price, to be made in lump sum, or at the most two installments according to a schedule specified in the **SCC**, subject to the requirements in Annex "E" of the 2016 revised IRR of RA No. 9184.

14. Progress Payments

The Contractor may submit a request for payment for Work accomplished. Such requests for payment shall be verified and certified by the Procuring Entity's Representative/Project Engineer. Except as otherwise stipulated in the **SCC**, materials and equipment delivered on the site but not completely put in place shall not be included for payment.

15. Operating and Maintenance Manuals

- 15.1. If required, the Contractor will provide "as built" Drawings and/or operating and maintenance manuals as specified in the **SCC**.
- 15.2. If the Contractor does not provide the Drawings and/or manuals by the dates stated above, or they do not receive the Procuring Entity's Representative's approval, the Procuring Entity's Representative may withhold the amount stated in the **SCC** from payments due to the Contractor.

Section V. Special Conditions of Contract

GCC Clause	
2	No sectional completion of work
4.1	The Procuring Entity shall give possession of all parts of the Site to the Contractor upon the receipt of Notice to Proceed
6	The site investigation reports are: None
7.2	Fifteen (15) years.
10	No dayworks are applicable to the contract.
11.1	The Contractor shall submit the Program of Work to the Procuring Entity's Representative within Ten (10) days from the receipt of the Notice of Award.
11.2	The amount to be withheld for late submission of an updated Program of Work is None.
13	The amount of the advance payment is 15% of the total contract price and to be made in lump sum.
14	Materials and equipment delivered on the site but not completely put in place shall not be included for payment.
15.1	The date by which "as built" drawings are required is within Fifteen (15) days upon the completion of the project.
15.2	The amount to be withheld for failing to produce "as built" drawings and/or operating and maintenance manuals by the date required is None.

Section VI. Specifications

Project Name: Design and Build of a Four (4) Legged Three Hundred (300) Feet TV Broadcast Tower including the Transmitter Building with Roof deck and Perimeter Fence for PTV Davao Del Norte of the People's Television Network, Inc. (PTNI)

Location: Capitol Compound, Mankilam, Tagum City, Davao Del Norte

SCOPE OF WORKS (SOW)

I. GENERAL INSTRUCTIONS

a. Technical Components and Track Records

1.1 The Bidder/Contractor shall exhibit that it has technical capability and experience in **Design and Build of a four (4) Legged Broadcast/Communication Tower and Equipment Building.**

1.2 The Bidder/Contractor must have an experience of having completed a Single Largest Completed Contract (SLCC) that is similar to this project, equivalent to at least fifty percent (50%) of the Approved Budget for the Contract (ABC). The bidder shall submit proofs of their completed projects such as Purchase Order (PO), Owner's Certificate of Final Acceptance issued by the project owner other than the contractor or a final rating of at least Satisfactory in the Constructors Performance Evaluation System (CPES). In case of contracts with the private sector, an equivalent document shall be submitted.

For this purpose, similar contracts shall refer to contracts which have the same major categories of work. Projects referred to as similar shall refer to the Design and Build of a four (4) Legged Broadcast/Communication Tower.

1.3 The bidder/contractor must be an ISO 9001:2015 certified to be eligible in this project.

II. GENERAL SCOPE

1. BACKGROUND AND OBJECTIVE

People's Television Network, Inc. (PTNI) is proposing to build and establish a provincial station, a One (1) – Storey Transmitter Building with three hundred (300) Feet Four (4) Legged Two Hundred Fifty TV Broadcast Tower which will be situated at Capitol Compound, Mankilam, Tagum City, Davao Del Norte.

The project implementation shall adopt the Design and Build Scheme guidelines under the Republic Act 9184 and its Revised Implementing Rules and Regulations.

2. PROJECT DESCRIPTION

The Project title is Supply, Delivery, Design and Build of a Four (4) Legged Three Hundred (300) Feet TV Broadcast Tower including the Transmitter Building with Roof deck and Perimeter Fence for PTV Davao Del Norte of the People's Television Network, Inc. (PTNI). This will support the PTNI operations in Tagum City, Davao Del Norte with lot area of 1000sqm.

III. PRE-DETAILED DESIGN

The prospective bidder must conduct site inspection and submit a certification of site inspection duly signed by PTNI representatives.

The prospective bidder shall refer to the Geotechnical Investigation Report in Annex "A" as basis for the detailed Preliminary Design.

The winning bidder/contractor must conduct **site inspection** to validate existing site conditions, environmental conditions, site survey, geotechnical conditions and other project data and information that is necessary for the project design definition and detailed design.

Engineering Surveys and Investigations include but shall not necessarily be limited to the following activities:

- i. **TOPOGRAPHIC SURVEY:** Carry out necessary field survey of the site. It is envisaged that the survey would include staking, establishing horizontal control points and benchmarks and all necessary cross-sections and topographic surveys of the proposed structure. The accuracy of surveys and requirements for closure of horizontal and levelling traverses will be as directed.
- ii. **SOILS AND MATERIALS INVESTIGATIONS:** The winning Designer-Builder shall perform borings and detailed soil investigations of the proposed site. Analysis and testing will be carried out in accordance with the latest AASHTO and ASTM Standards.

IV. DETAILED DESIGN WORKS

The bidder shall prepare and undertake the detailed architectural and engineering design within the government cost range and established preliminary design requirements.

The contractor must adhere to the National Building Code of the Philippines in the design but not limited to the following:

- | | |
|---------------------------------|---|
| a. Architectural Design | g. Mechanical Design |
| b. Floor Plan Layout | h. Fire Protection and Suppression Design |
| c. Civil and Engineering Design | i. I.T. and Computer Network Cabling/Electronics Design |
| d. Structural Design | j. Materials and Finishing Schedule |
| e. Electrical Design | |
| f. Sanitary and Plumbing Design | |

1. Architectural Design Works

Architectural design and finishes shall conform but not limited to the following:

- 1.1 Floor covering materials shall be 600mm x 600mm polished granite tiles in Transmitter room, 400mm x 400mm ceramic floor tiles for guard house, 300mm x 300mm non-skid ceramic floor tiles for comfort rooms and pantry, plain cement finish with epoxy paint for Electrical and Genset room.
- 1.2 Roof deck slab and concrete roof shall be plain concrete topping finish with multi-co polymerized resin (cold-applied) Waterproofing of concrete slab roofing.
- 1.3 Windows shall be 1200mm x 1200mm sliding window in aluminum frame analog finish with grills and complete locking devices and accessories.
- 1.4 Exterior and Interior walls shall be plain cement plastered painted (off-white) finish.
- 1.5 View Glass between Quarter's room and Transmitter room shall be 10mm clear glass with dimensions of 1600mm x 900mm.
- 1.6 Canopy shall be solid mini corrugated polycarbonate.
- 1.7 Provision of office tables, office chairs and Double-Deck (steel) with Mattress

2. Site Development Design Works

Site development design shall include perimeter fence with main entrance gates, perimeter lighting, storm drainage, manholes, fuel tank, utilities and other facilities necessary for the operation of PTNI.

- 2.1 Perimeter fence shall be combination of chb and steel matting with at least 2.5 meters high.
- 2.2 Main Access gates shall be at least 3 meters wide and 2.5 meters high.
- 2.3 Power house shall be in accordance with the standards set by the local power utility. Water supply facilities shall meet the requirements set by the local water utility provider.
- 2.4 Site development shall include the design and construction of Power house/ Genset Room & Electrical Room.

3. Structural Design Works

The basic structural engineering design for this project shall conform primarily to the National Structural Code of the Philippines 2015, 7th Edition. Other generally accepted standards shall be used as secondary bases. The contractor shall perform structural design investigation and analysis and other structural design study for foundation, columns, beams, slabs and other structural member of the project.

3.1 TOWER AND FOUNDATION

The design criterion shall be applied to the structural analysis of proposed Tower and supporting foundation including its sub-structures.

91.44 meters (300 feet) Four (4) Legged Self Supporting Tower & Foundation with provisions for DTT Spline Adapter.

The Designer/Builder shall design the tower with four (4) rest-platforms and two (2) working platforms and vertical man-ladder in the given material specifications:

- i. Landings- Heavy Duty Expanded metal
- ii. Vertical Man-ladder- round steel guard
- iii. Tower- Structural Steel (Tubular Pipe) in accordance to ASTM 36 or approved equivalent
- iv. Tower Painting- High Build Self Priming Epoxy, Polyurethane Top-coat

3.1.1 Design Loads

The minimum design loads for the structure and supporting foundation shall be the weight of the structure including all appurtenances and attachment, lateral forces effects, differential movements, and restrained dimensional changes. Design loads and forces are those resulting from dead loads, live loads and lateral loads acting in the most critical combinations, using the appropriate load factors recommended by the governing codes. The basic load types and their corresponding magnitude are as follows:

3.1.1.1 Wind Load

The structure and every portion thereof shall be designed and constructed to resist the wind effects determined in accordance to the requirements NSCP 7th Edition, 2015.

Wind Pressure:	Please adhere to the updated government requirement
Wind Velocity:	300 Kph basic wind speed
Exposure:	C
Importance Factor:	per NSCP 2015, 7 th edition
Gust Effect Factor:	per NSCP 2015, 7 th edition
Force Coeff. Per tower type:	per NSCP 2015, 7 th edition

3.1.1.2 Seismic Load

The basic design seismic load for the structure and portion thereof shall design based on the provision of the National Structural Code of Philippines 2015, 7th Edition.

Seismic Force:	per NSCP 2015, 7 th edition
Importance Factor:	1.50
Seismic Zone:	4
Seismic Source Factor:	per NSCP 2015, 7 th edition
Near Source Factor:	per NSCP 2015, 7 th edition

3.1.2 Antennas and Appurtenances

The tower and supporting foundation shall be designed to carry and resist all loads from the tower antennas, including all appurtenances such as mounting brackets, cable ladder, antenna cables, etc.

ANALOG AND DIGITAL ANTENNA SYSTEM WEIGHT

ANTENNA DESCRIPTION	QTY/SET	ANTENNA WT. (kg.)
VHF Antenna:	32 panels	14 kg/panel = 448 kgs
Power Divider	2 units	30 kgs
Feeder/Harness/Accessories	2 units	32 kgs
1-5/8 Heliac Transmission Cable	2 units	2.24 kg x 75m (approx. length used at tower) = 168 kgs
Brackets and support	2 lots	128 Kgs
Microwave Comms/ICT Equipment		
Receiver	2 units	2 x 75 kgs = 150 kgs
Cable	2 units	2 x 20 kgs = 40 kgs
UHF ANTENNA (DTX)		
Slot type Digital Antenna top mount and mounting support	2 sets	= 500 kgs
1-5/8 Heliac Transmission Cable	2 units	2.24 kgs x 75m (approx. length used at tower) = 168 kgs
TOTAL WEIGHT =		= 1664 kgs (say 1800kg)

3.2 Material Properties

The material specification and specified design data for structural evaluation and detailing of concrete and steel members shall be in accordance with the following materials strengths specified.

3.2.1 CONCRETE

The strength is in accordance with the test method using cylinder type test pieces as PNS/ASTM C39. The specified compressive strength (f_c) at 28th days age and laboratory cured shall be as follows:

- a. $f_c = 21.0$ MPa for Pedestals and Foundations
- b. Modulus of Elasticity, $E_c = 4700 f_c$
- c. Modulus Rupture, $f_r = 0.67 f_c$

3.2.2 REINFORCING STEEL

Reinforcing steel shall be deformed and shall meet ASTM A706. The minimum yield strength shall be as follows:

- a. $f_c = 21.0$ MPa for Pedestals and Foundations
- b. For $\varnothing 16$ and smaller $f_y = 275$ MPa (40 ksi)
- c. For $\varnothing 20$ and larger $f_y = 414$ MPa (60 ksi)
- d. Modulus of Elasticity, $E_s = 200,000$ MPa
- e. ASTM A615 (weldable) shall be permitted if:
 - The actual yield strength based on mill tests does not exceed by more than 125 MPa (retests shall not exceed this value by more than an additional of 21 MPa); and
 - The ratio of the actual tensile strength to the actual yield strength is not less than 1.25.

4. Mechanical Design Works

Mechanical design works shall include air-conditioning and ventilation system, fire protection and fire Alarm system.

4.1 Air-Conditioning and Ventilating System

- a. Transmitter room shall have a Split Type Floor Mounted Inverter type Aircon Units.
- b. Comfort rooms, electrical room/genset room shall be provided with exhaust fan ventilating system. Air ventilation shaft shall be galvanized iron and installed above ceiling lines.

4.2 Fire Protection and Suppression System

- a. Electrical room/ Genset room shall have a Portable ABC classification 10 lbs. HFC 236FA "FE 36" fire extinguishers
- b. Fire pump shall start automatically.
- c. Smoke detectors and alarm bells shall conform to the minimum requirements of the code. Smoke detection fixtures shall be IP based system with control panels and monitoring system.
- d. Pump and motor system shall be incorporated in the design. It should accommodate the minimum requirements of the operation. All pumps, jockey and fire pumps should be Underwriters Laboratories (UL) listed and FM approved. Fire protection and suppression system is subject for testing and commissioning.

5. Sanitary and Plumbing Design Works

The contractor shall design complete plumbing system including potable water line, sewer line, sanitary system, storm drain system including fixtures, piping system, fittings and appurtenances, equipment and machinery, facilities and other facility that is necessary for the project. The use of low-flow efficient fixtures and equipment is recommended. Technical drawings and specifications shall be clearly and properly defined.

- 5.1 Sanitary and plumbing design shall conform but not limited to the following:
- 5.1.1 Sanitary waste shall be drained by gravity to the sewer line system.
 - 5.1.2 All drainage and sewer line shall be concealed, unexposed and covered type system.
 - 5.1.3 Drainage plan shall be properly presented including flow, access hole distance, pipe and fitting sizes, invert elevations and other necessary information for the construction.
 - 5.1.4 Catch basin and culvert design shall be in accordance to the design requirements.
 - 5.1.5 Waste water from pantry sink shall be provided with grease trap under the sink.
 - 5.1.6 Septic tank shall be 2-chamber system.
 - 5.1.7 Storm drainage design shall be adequate.
 - 5.1.8 All fixtures shall be individually vented.
 - 5.1.9 Minimum slope for pipes shall be not lesser done 1 ½ %.
 - 5.1.10 All roof drain shall be provided with strainer (dome type).
 - 5.1.11 Storm drainage system for floors above grade level shall be drained by gravity to the drainage line at ground level.
 - 5.1.12 Provide hose bib for site green areas, pump rooms, parking areas, and other utility rooms which requires water supply.
 - 5.1.13 Provide Rain Water Collector Tank.
 - 5.1.14 Booster pump and pressure tank, if any, shall be provided to meet the required minimum pressure.
 - 5.1.15 Operating pressure of fixtures shall be considered.
 - 5.1.16 Occupant water demand as per code requirement.
 - 5.1.17 Water storage tank shall be designed to accommodate fire and domestic uses where the number and size shall be supported with design computations.
 - 5.1.18 Application, facilitation and Installation of permanent water supply connection from Local Service provider shall be included in the scope of work of the contractor.

5.2 Material specifications guidelines are the following:

- 5.2.1 Sewer and Vent System - Pipes, vents, branch vents, waste lines and fittings shall be Series 1000 Polyvinyl Chloride (PVC), locally available.
- 5.2.2 Storm Drainage System:
 - a. Roof drain shall be dome-type brass strainer.
 - b. Floor drain shall be square type stainless.
 - c. Downspouts and collectors shall be PVC including fittings.
- 5.2.3 Water Distribution System:
 - a. Potable and non-potable water lines and fittings shall be Polypropylene Pipes (PPR) PN-20 with Fusion Joint Connections DIN 16968/DIN 16969.
 - b. Fire water line shall be Black Iron (B.I.) pipe schedule 40.
- 5.2.4 Fixtures:
 - a. Water closet shall be flush valve type, siphon jet and low flow type fixtures with bidet.
 - b. Lavatory shall be under counter type.
 - c. Kitchen sink and utility sink shall be stainless and anti-bacterial type.

6. Electrical Design Works

- 6.1 All electrical works herein included shall conform to the provisions of the latest edition of the Fire Code of the Philippines; Philippine Electrical Code and/or as Local Government Code or as specified by PTNI.
- 1. General Lighting
 - 2. Convenience Outlet

3. Grounding System
 - a. Building Grounding
 - b. Equipment/System Grounding
 - c. Tower Grounding
 4. Lightning Arrester
 5. 150kVa Prime Power Generator Set
 6. Circuits Breakers and Panel boards
 7. Permanent Electric/Power Supply
 8. Obstruction Lights
 9. Other facilities and equipment that are necessary for the project
- 6.2 All outdoor and exposed electrical conduits shall be PVC except for the service entrance. All underground conduit installations shall be encased entirely in concrete.
 - 6.3 All outdoor wire gutter, L-condulets, and conduits shall not be installed directly along the floor line or roof deck to protect them from corrosion and water damage. Use hot dip galvanized clamps and brackets.
 - 6.4 All electrical equipment and metal enclosures of conductors (metal raceway, gutters, boxes, panel board enclosures and fittings) shall be effectively bonded together to assure electrical continuity and the capacity to conduct safely any fault current likely to be imposed on them. Proper installation of grounding system shall conform to Article 4.2 (Grounding) of the PEC.
 - 6.5 All electrical panel boards and wire gutters shall be provided with adequate grounding for its metal enclosure.
 - 6.6 All wire and cable terminations inside electrical panels shall be provided with appropriate terminal lugs for bolted termination.
 - 6.7 All exposed electrical pipes and metal conduits shall be pre-coated with anti-rust and coated with gray or white acrylic paint.
 - 6.8 All grounding terminals/rods shall be tapped to one grounding loop. Grounding of the transmitter building, equipment, tower, genset, perimeter lights and other metallic material included in the site.
 - 6.9 All lighting down-conductors provided for the antenna mounting poles and towers shall be routed directly downward to the ground terminal.
 - 6.10 Whenever necessary to bend the grounding cable run, long elbow conduits shall be used. Use of condulets for grounding is not allowed.
 - 6.11 Generator Set should be Prime Power Generator set silent type. If necessary, a Noise blocker and/or additional silencer must be provided by the winning bidder at their own cost.
 - 6.12 The winning bidder shall also provide Automatic Transfer Switch (ATS) as part of Generator Set.
 - 6.13 Application, facilitation and installation of permanent power supply connection from Local Service provider shall be included in the scope of work of the contractor.

7. Electronics Design Works

The design shall include TV broadcast operations, IT communication system, LAN system, provisions on CCTV system and internal IT operations. Basic electronics requirements shall be incorporated to the design.

- 7.1 Electronics design shall conform but not limited to the following:
 - 7.1.1 Telephone
 - 7.1.2 Data/LAN

7.1.3 Closed Circuit Television (CCTV)

7.2 Application of Internet connection from Internet Service Provider shall be included in the scope works of the contractor.

V. DESIGN AND CONSTRUCTION SCHEDULE

The project shall be completed and turn-over the project **within one hundred and fifty** (150) calendar days reckoned from the date stated in the Notice to Proceed (NTP) to be issued by the Agency (PTNI).

The winning bidder shall submit final detailed design plans, materials specifications and finishes, and detailed bill of quantities within fifteen (15) days upon the date of receipt of Notice to proceed for final approval by the **Design and Build Committee** or **Technical Working Group**.

Upon the approval of the final detailed design and construction plans, the contractor shall secure all the necessary permits prior for construction.

VI. CONSTRUCTION KEY PERSONNEL

The Contractor shall provide adequate and qualified staff to perform the services described herein. The general qualifications for the key personnel are as follows:

1. DETAILED DESIGN KEY PERSONNEL

- 1.1 **Structural Engineer**, must be duly licensed Structural Engineer with at least 15 years of experience in structural design and has undertaken projects with project cost of at least 50% of the ABC; with substantial knowledge in structural and earthquake design of building and broadcast tower structures.
- 1.2 **Design Architect**, must be duly licensed and an active member of Integrated and Accredited Professional Organization of Architects (IAPOA) with at least 10 years of experience in the architectural design of commercial, academic or institutional facilities and corporate buildings, site planning and landscaping.
- 1.3 **Professional Electrical Engineer**, must be duly licensed with at least 10 years of experience in building electrical design, lighting, power distribution, switches and panels and preferably knowledgeable in efficient lighting technologies and energy management.
- 1.4 **Professional Mechanical Engineer**, must be duly licensed with at least 5 years of experience in mechanical design and installations of HVAC and fire protection and suppression systems and preferably knowledgeable in emergent, alternative energy-efficient HVAC technologies.
- 1.5 **Professional Electronics Engineer**, must be duly licensed with at least 5 years of experience in building electronics design, as well as fire detection and alarm systems in buildings.
- 1.6 **Sanitary Engineer/ Registered Master Plumber**, must be duly licensed with at least 5 years of experience in the design of building water supply and distribution systems, plumbing and sanitary systems and preferably knowledgeable in and emergent, alternative effluent collection and treatment systems.
- 1.7 **Geotechnical Engineer**, must be duly licensed Civil Engineer with a post graduate degree in Geotechnical Engineering or PICE Specialization with at least 5 years of experience in geotechnical evaluation.
- 1.8 **Cost/ Quantity/ Specifications Engineer**, must be duly licensed Civil Engineer with at least 5 years of experience in the preparation of technical specifications and detailed analysis of all applicable unit prices.

2. CONSTRUCTION KEY PERSONNEL

- 2.1 Project Manager/Structural Engineer** , a duly licensed Structural Engineer with at least ten (10) years of experience in Structural Engineering and member of the Association of Structural Engineers of the Philippines (ASEP) with substantial knowledge in the structural design of broadcast towers in accordance with the National Structural Code of the Philippines, experienced in the direction and administration of activities pertinent to the planning and design of broadcast towers, transmitter buildings and site development.
- 2.2 Project Manager for Construction**, a duly licensed Civil Engineer with at least five (5) years of experience in the construction of Broadcast Towers and experienced in the direction and administration of activities pertinent to the retrofitting works of broadcast towers.
- 2.3 Cost/Quantity/Specs Engineer**, with wide experience in the preparation of tender documents and technical specifications, and in the preparation of detailed analysis of all applicable unit prices.
- 2.4 Project Engineer**, a duly licensed Civil Engineer and/or an Electronics Engineer with at least three (3) years of experience in the supervision/implementation of building rehabilitation and broadcast tower projects.
- 2.5 Professional Electrical Engineer (PEE)**, a duly licensed Professional Electrical Engineer with at least five (5) years of extensive experience in tower electrical design and construction/retrofitting and has substantial knowledge in the electrical systems design of broadcast tower and tower facilities.
- 2.6 Professional Electronics Engineer (PECE)**, a duly licensed Professional Electronics Engineer with at least five (5) years of extensive experience in TV antenna design.
- 2.7 Safety Officer**, must have undergone the prescribed 40 hours of Construction Safety and Health Training (COSH), duly supported by a Certificate of Completion issued by any DOLE/BWC accredited entity with at least three (3) years of experience in construction of tower projects.

VII. MINIMUM REQUIREMENTS FOR CONSTRUCTION OCCUPATIONAL SAFETY AND HEALTH (COSH) PROGRAM

The contractor shall comply the minimum requirements for COSH set by the Department of Labor and Employment (DOLE).

VIII. SUBMITTALS AND DELIVERABLES

The prospective bidder / contractor shall submit the following during the Opening of Bids.

- i. Preliminary Conceptual Design Plan**
- ii. Detailed Reports**

Failure to comply with this section shall be a ground for disqualification. All submittals are subject for review and approval of the PTNI-DBC and/or PTNI-TWG.

a. Preliminary Conceptual Design Plans

The prospective bidder / contractor shall submit the preliminary conceptual subject for approval by the procuring entity, but not limited to the following minimum requirements:

ARCHITECTURAL PLANS

1. Site Development Plan
2. Floor Plans
3. Elevations of All Sides
4. Building Sections
5. Reflected Ceiling Plans
6. Schedule of Doors and Window
7. Schedule of Interior Finishes
8. Schedule of Exterior Finishes
9. Schedule of Floor Finishes
10. Schedule of Wall Finishes
11. Schedule of Ceiling Finishes
12. Roof Slab Plan
13. Other Architectural Miscellaneous Details

STRUCTURAL AND CIVIL PLANS

1. Structural General Notes and Specifications
2. Foundation Plan and Details
3. Slab on Grade plans and Details
4. Floor Framing Plans and Details
5. Roof Deck Framing Plans
6. Schedule of Footings, Columns, Slab, Beams/Girders and Details
7. Schedule of Reinforcement
8. Other Structural Details

ELECTRICAL PLANS

1. Electrical General Notes and Specifications
2. Lighting Layout Plans
3. Power and Convenience Outlet Layout Plans
4. Grounding System Layout Plans
5. Schedule of Loads
6. Single Line Diagram
7. Genset House Plans
8. Electric Service Entrance Plans
9. Air-Condition System Power Layout Plans
10. Equipment and Machineries Power Layout Plans
11. Other Electrical Miscellaneous Details

MECHANICAL PLANS

1. Mechanical General Notes and Specifications
2. Pumps and Motors Layout Plans and Details
3. Air-Condition System Layout Plans
4. Air-Condition System Details
5. Fire Suppression System Layout Plans and Details
6. Other Mechanical Miscellaneous Details

SANITARY AND PLUMBING PLANS

1. Sanitary and Plumbing General Notes and Specifications
2. Water Line Layout Plans
3. Sanitary and Plumbing Layout Plans
4. Plumbing System Isometric Diagram
5. Water Storage/Rain Water Collector Tank Layout Plans and Details
6. Toilet and Comfort Room Fixture Layout Plans
7. Septic Tank Details
8. Other Sanitary and Plumbing Miscellaneous Details

ELECTRONICS PLANS

1. Electronics General Notes and Specifications
2. Data (LAN) / Telephone Layout Plans
3. CCTV Cable Layout Plans
4. Fire Detection and Alarm System Layout Plans and Details
5. Other Electronics Miscellaneous Details

b. Detailed Reports

1. General Notes and Technical Specifications describing type and quality of materials and equipment to be used, manner of construction and the general conditions under which the project is to be constructed.
2. Detailed Bill of Qualities, Cost Estimates including a summary sheet indicating the unit prices of construction materials, labor rates and equipment rentals.
3. Detailed Unit Price Analysis (DUPA) showing sources of data and all calculations made in determining the unit price of each item of work, including profit factor, overhead, contractor's tax, etc.
4. Summary of Works
5. Design and Construction Methods
6. List of Design and Construction Personnel
7. Value of Engineering Analysis of Design

All detailed reports shall be prepared on a Legal-size bond paper on ring/book bounded document.

c. As-Built Plans

The contractor shall prepare and submit As-Built Plans based on the actual construction accomplishments and emplacement of materials, equipment, furnishings, utilities and other information that is necessary for the operations and maintenance of the buildings.

The contractor shall also submit operations and maintenance manuals of the emplaced equipment and machineries for the reference of the operations and maintenance personnel.

d. Details of Submittals and Deliverables

Preliminary Conceptual Design Plans

- i. Number of Copies - 3 copies / sets
- ii. Document Size - 24" x 36" White/Blue Print Copy

Detailed Reports

- i. Number of Copies - 3 copies / sets
- ii. Document Size - 8.5" x 13" Legal Size
- iii. Specifications - Ring/Book Bound

As-Built Plans

- i. Number of Copies - 3 copies per set
- ii. Document Size - 24" x 36" Plot (Tracing) & Blueprints
- iv. E-file (AutoCAD File version 2016) in USB Flash Drive

IX. CONSTRUCTION WORKS/ CONSTRUCTION STANDARDS

1. As a rule, contract implementation guidelines for procurement of infrastructure project shall comply with Annex "E" and guidelines for the implementation of contracts for DESIGN AND BUILD infrastructure projects shall comply with Annex "G" of IRR, RA 9184.
2. Delivery of Tower, Air-conditioning Unit (ACU), Automatic Transfer Switch ATS, Digital Transfer Switch (DTS), etc. to PEOPLE'S TELEVISION NETWORK, INC.'s site. The winning bidder shall test the items and conduct physical count prior to delivery on site upon PTNI's advice to proceed with the delivery.
3. All construction works may commence upon the approval of PTNI. Any variation or conflicts between the actual and the construction plan shall be notified to PTNI immediately for approval of the revision(s).

4. All materials for testing such as rebars, concrete, soil fill, welding and CHB shall be notified to the PTNI's duly authorized representative. The Contractor shall submit all test result reports to PTNI.
5. All steel works including the anchor bolts shall be set and leveled accurately and shall be free from any water, dirt and excessive corrosion before scheduling for concrete pouring. Inspectors from the tower supplier shall witness this activity and shall certify the accuracy of the setting.
6. All tower foundation pouring activity shall be notified to for pre-inspection of reinforcement settings. Separate concrete cylinder for testing before pouring and shall be inspected by a PTNI or duly authorized representative.
7. Foundation reinforcement shall be pre-fabricated, bended and then delivered on site.
8. Required backfilling/soil materials should first pass the field density test. If in case the soil field density test failed, the Contractor shall replace it with a suitable imported soil. All excess soil on site shall be removed from the property and may be used in the right-of-way construction as binder for the gravel bedding. All backfilling/soil materials shall be well compacted.
9. All soil retaining materials will be required whenever necessary. It is the Contractor's obligation to ensure the soil will not erode, slide or roll on to workers or damage adjacent facility structures.
10. Soil poisoning prior to construction of the building structure should be applied on the ground to prevent insects and grass from growing.
11. All tower steel members and accessories such as cable ladder, microwave bracket shall be hot-dip galvanize and painted. Observing the exact color painting scheme, the Contractor shall inform PTNI that the broadcast equipment antennas and cables are ready for installation concurrent to the completion of the rest painting parts.
12. All the broadcast facilities and equipment shall be reliable accessibility for operations and maintenance by constructing segregated right-of-way, access road, dirt road or walkway for equipment / antenna access ladder catwalk way for building sites.
13. The site shall have a grounding system and a permanent electric power source. The grounding and insulation test shall be performed upon the completion of all the electrical and grounding works preferably when the site is still not operational. PEOPLE'S TELEVISION NETWORK, INC authorized representative shall witness all tests. If in case the test fails to reach the allowable readings, the Designer-Builder shall rectify, replace or add the corresponding insulators or ground conductors until the readings achieve the allowable and schedule again another test inspection.
14. Monitoring inspections may either be scheduled or unscheduled site visits of the construction site. PEOPLE'S TELEVISION NETWORK, INC. has the right to inspect any on-going construction site randomly with or without the knowledge of the Contractor. Any concerns, suggestions and violations from the PEOPLE'S TELEVISION NETWORK, INC. Guidelines and Policies shall be raised in the weekly project construction meeting for the proper action.
15. The site can be considered ready for broadcast equipment installation if and only the following conditions are achieved:
 - All facilities and site development are completed.
 - At least temporary sufficient power supply is available
 - Passed the grounding and Insulation tests
16. Include design, supply of materials, tools and equipment needed to carry out the work, Pile cap, Tie Beams, if necessary, mobilization and demobilization subject for verification and approval of the head of the agency.
 - Bored Piles (subject to variation)
 - Caisson Piles (subject to variation)
 - Micro Piles (subject to variation)

X. SITE TURN-OVER, ACCEPTANCE AND CLOSE OUT DOCUMENTS

This includes but not limited to Utility contract, building permit for construction, occupancy permits and all required clearances, site folder, certificate of electrical inspection, mill and test certificates, concrete & reinforcing bars test results, etc. in hard and electronic copies.

1. The PTNI representatives will conduct Acceptance work inspection and punchlisting. All punchlist or defected works shall be rectified by the winning contractor/bidder.
2. The winning contractor/bidder shall secure fire safety clearance, occupancy permit, permit to operate set.
3. The winning contractor/bidder shall prepare site folder with the following content
 1. As-built
 2. All Permits and clearances
 3. Soil Test Reports
 4. Mill Certificates
 5. Galvanizing Certificate
 6. Concrete Strength Test results
 7. Rebar Tensile Strength Test results
 8. Tension Test for Plates
 9. Liquid Penetrant Test (LPT) on Welded Steel Structures
 10. Tower verticality check result and certification
 11. Warranties and manuals
 12. Electric, Water Contract Agreements
 13. Site keys
 14. And all other pertinent document necessary to complete the site folder (in hard and electronic copies)

XI. Applicable Codes, Standards and Specifications

The design shall be in accordance with all the applicable laws and regulations of the Government of the Philippines and with the applicable local codes and ordinances. A summary of the codes and industry standards to be used in the design shall be as follows:

Design Codes and Standards

- a. National Structural Code of the Philippines (NSCP), Volume 1- Buildings, Towers and Other Vertical Structures, seventh (7th) Edition 2015.
- b. American Code Institute (ACI) Publications:
 - i. AC 318-08 Building Code Requirement for Structural Concrete
 - ii. ACI 315-99 Manual of Standard Practice for Details and Detailing
 - iii. ACI 301-96 Specification for Structural Concrete for Buildings
- c. American Iron and Steel Institute (AISI) Publication:
- d. Specification for the Design of Cold-Formed Steel Structural Members
- e. American Society of Civil Engineer/Structural Engineers Institute
- f. Minimum Design loads for Buildings and Other Structures ASCE/SEI 7-95
- g. Uniform Building Code, UBC 1997

XII. WARRANTIES

The bidder shall guarantee that all items/materials supplied are free from **manufacturing defects and workmanship** for a minimum period of **two (2) years** from the date of final acceptance.

- 10.1 The Designer/Contractor should have **15 years warranty** for the **structural design of the tower and the transmitter building including generator house.**
- 10.2 The Contractor should immediately take precautionary measures to correct any abnormalities in all supplied items/materials within the above-mentioned warranty period. Any associated cost (i.e., shipment, delivery, etc.) in the importation of items/materials during the said warranty period should be in to the account of the Contractor.
- 10.3 The obligation under all warranties shall cover all repairs or Replacement of defective items/materials and improper workmanship.

Section VII. Drawings





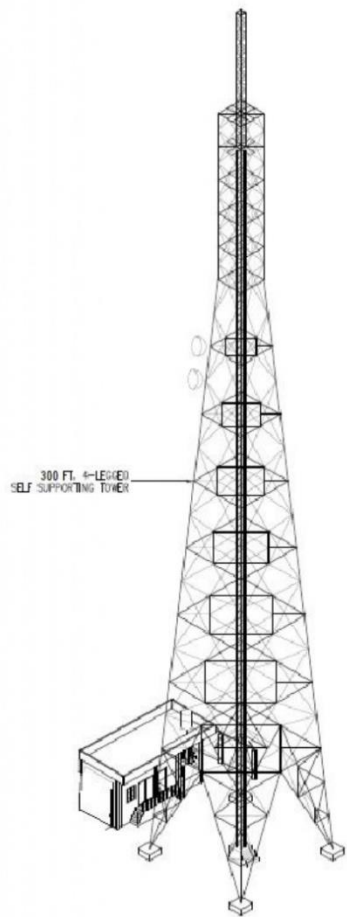

300FT. 4-LEGGED TOWER



 **LOCATION MAP**

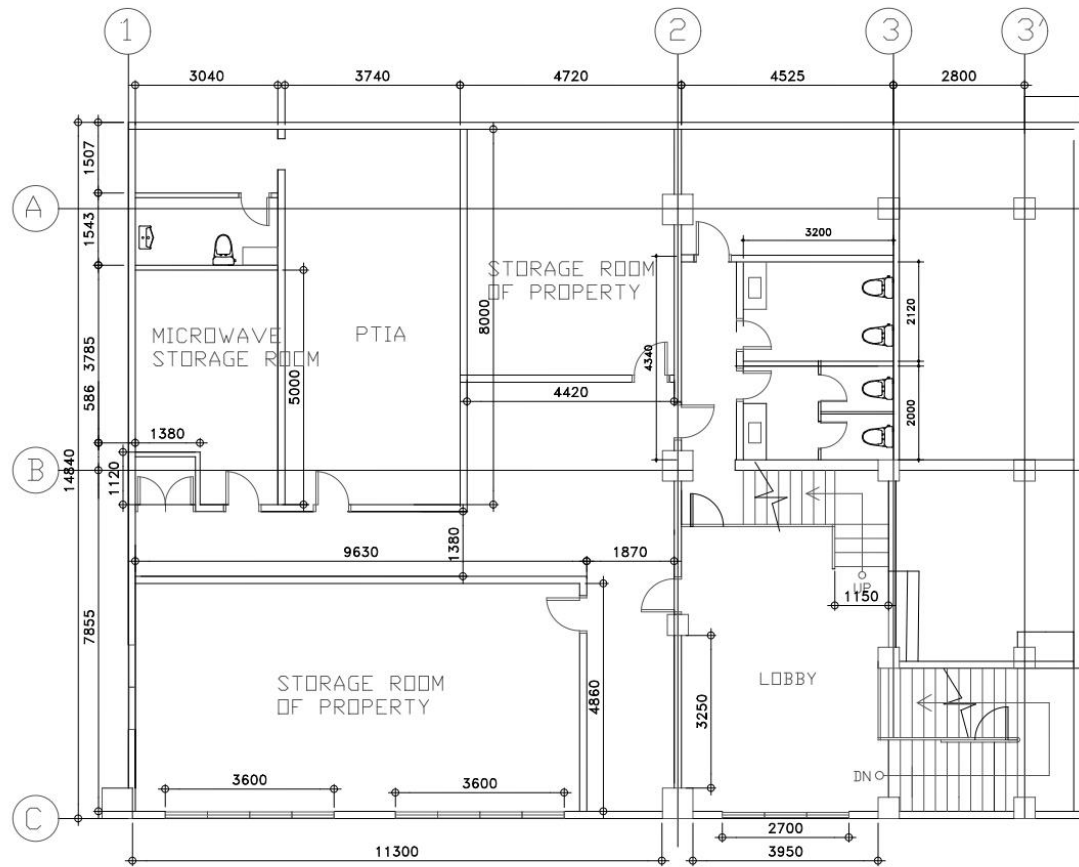

EXISTING PLAN SECOND FLOOR

TECHNICAL DESCRIPTIONS

LINE	BEARING	DISTANCE
1 - 2	S 25° 10' W	19.15 M
2 - 3	N 64° 50' W	52.19 M
3 - 4	N 25° 03' E	19.16 M
4 - 1	S 64° 50' E	52.23 M
AREA = 1,000 SQ. M		

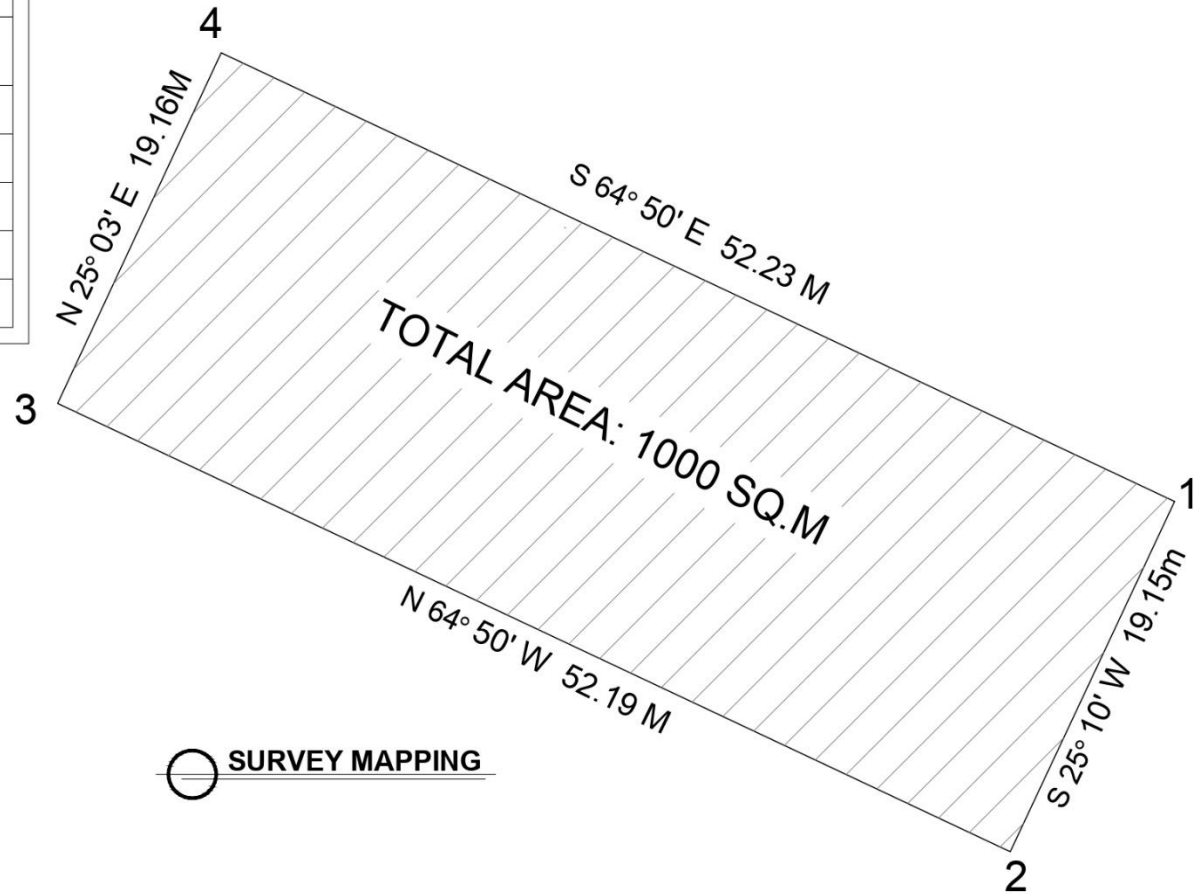

 **SURVEY MAPPING**

OWNER: PROJECT TITLE: DEDICATED BY: LISTED BY: RECOMMENDING APPROVAL BY: APPROVED BY: SHEET CONTENT: SHEET NO:

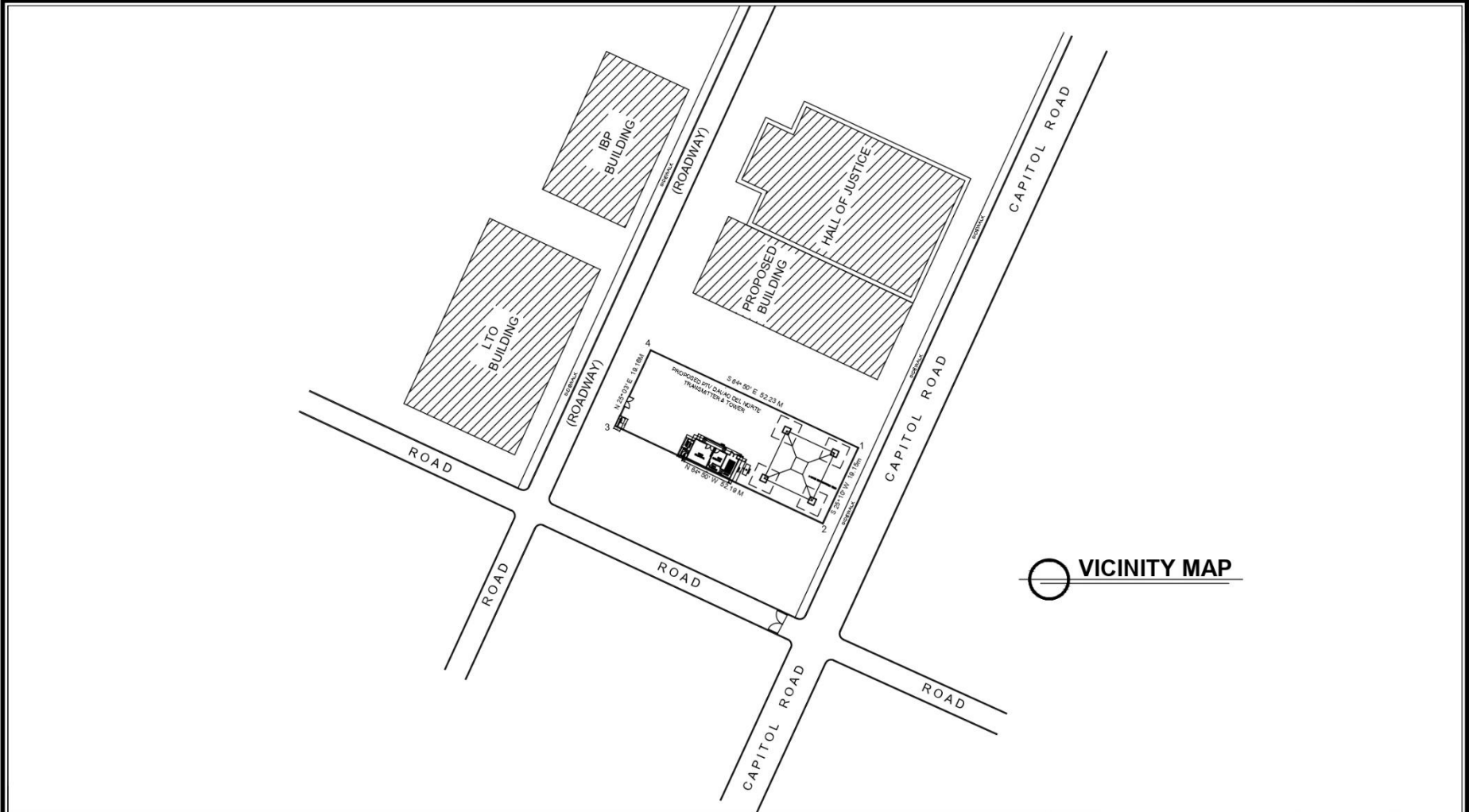

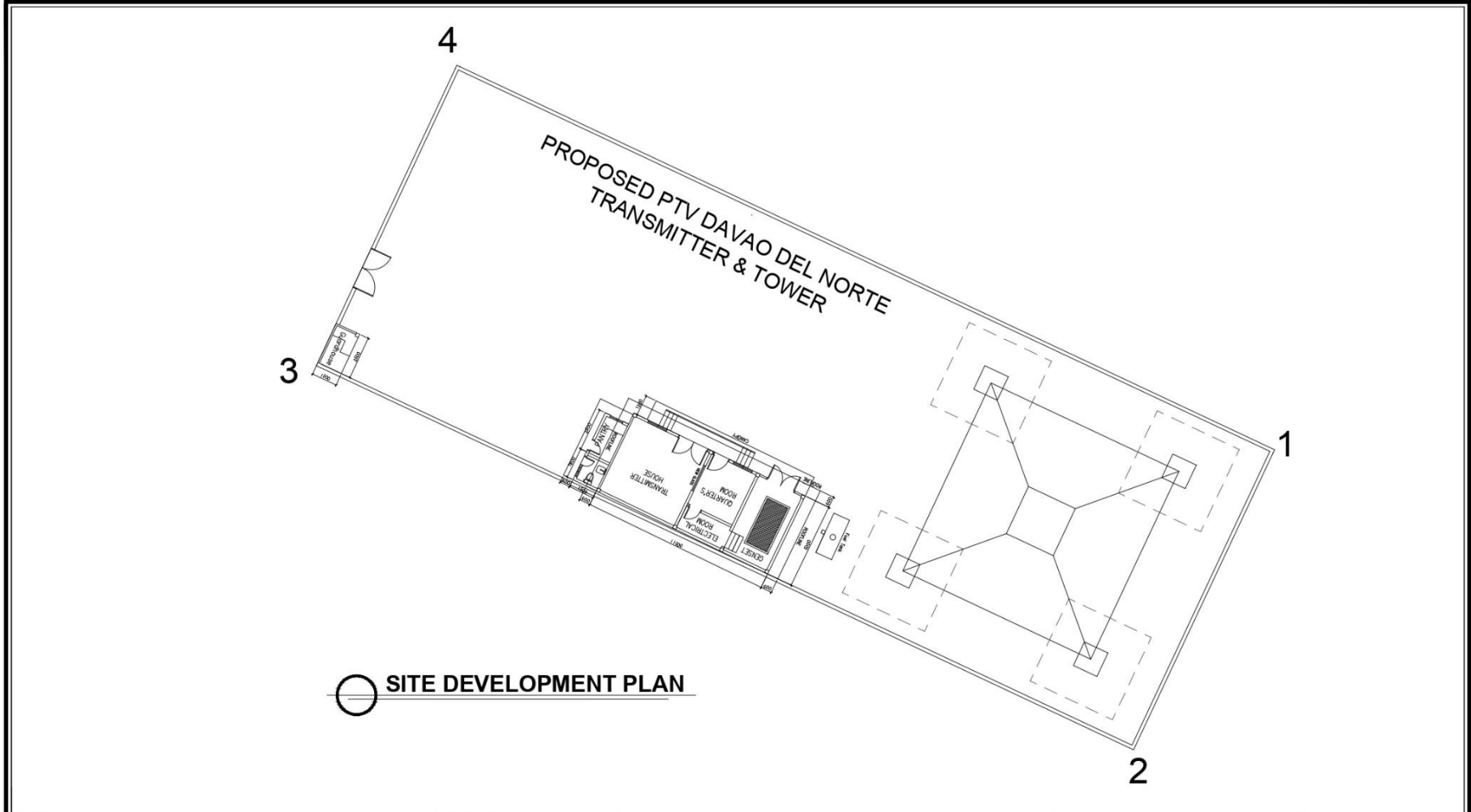

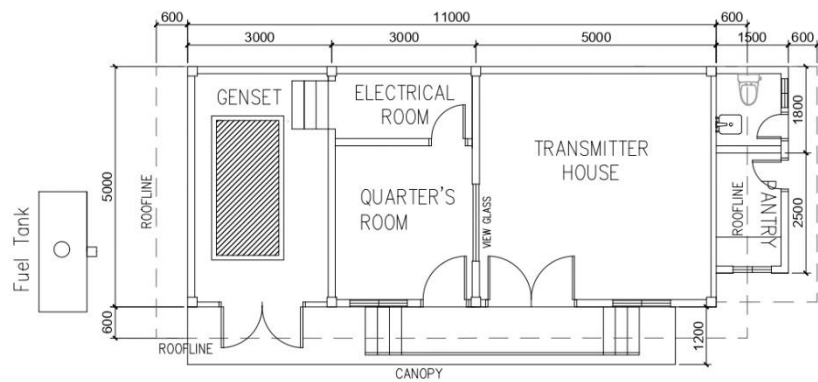

FLOOR PLAN (TRANSMITTER BLDG.)

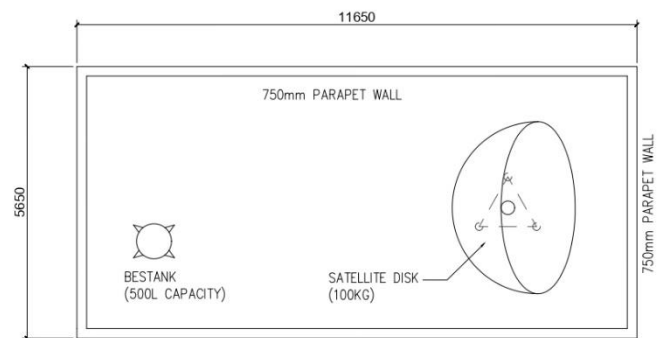

ROOF DECK PLAN

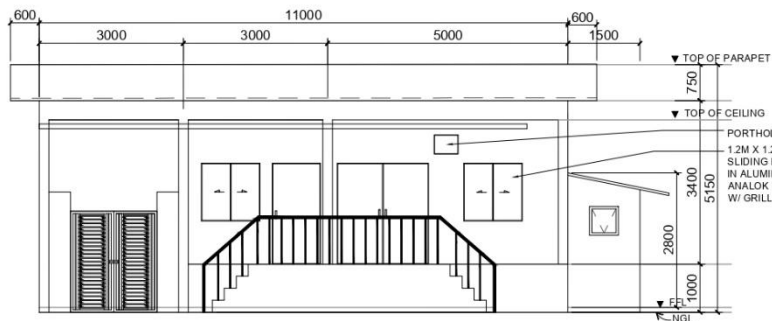

FRONT ELEVATION

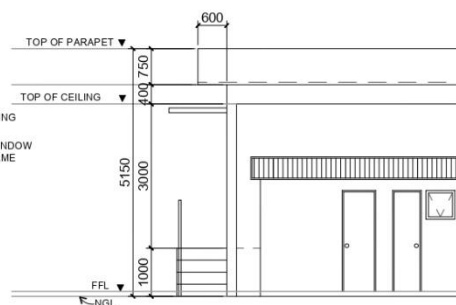

RIGHT SIDE ELEVATION

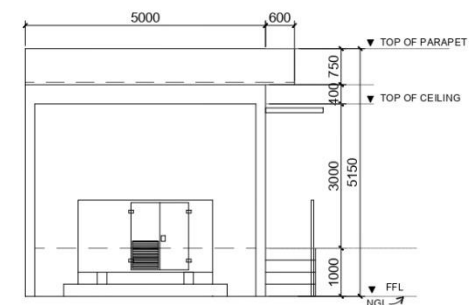

LEFT SIDE ELEVATION

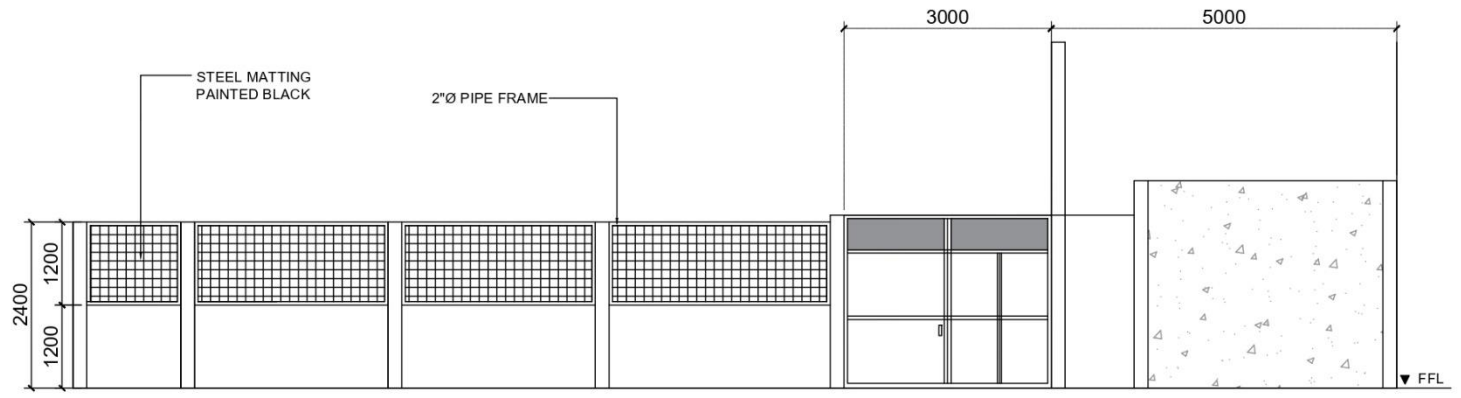

○ FRONT ELEVATION

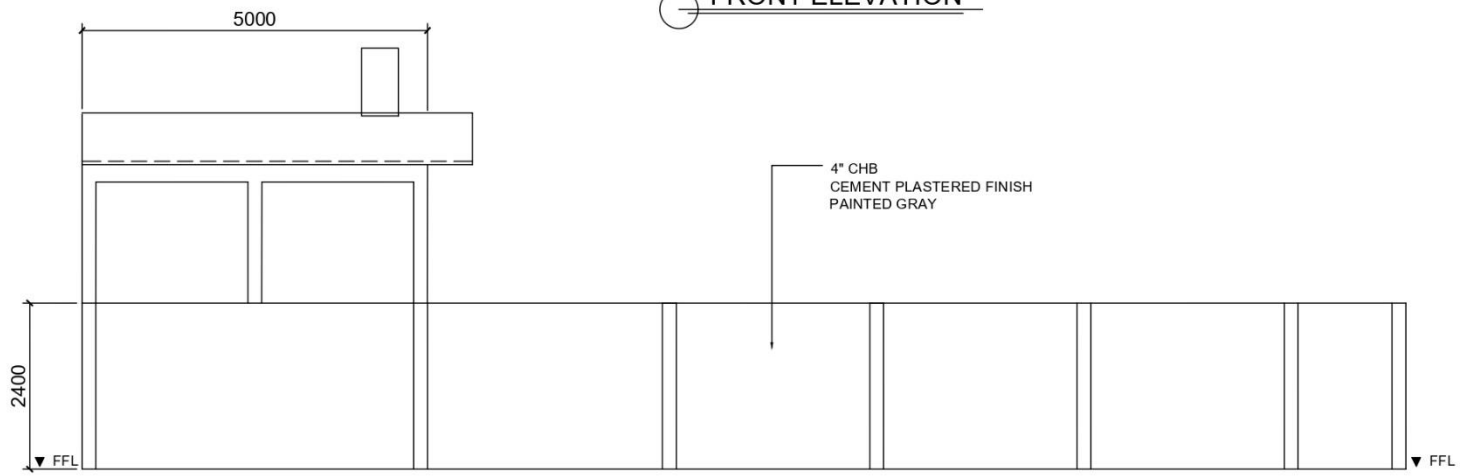

○ REAR ELEVATION

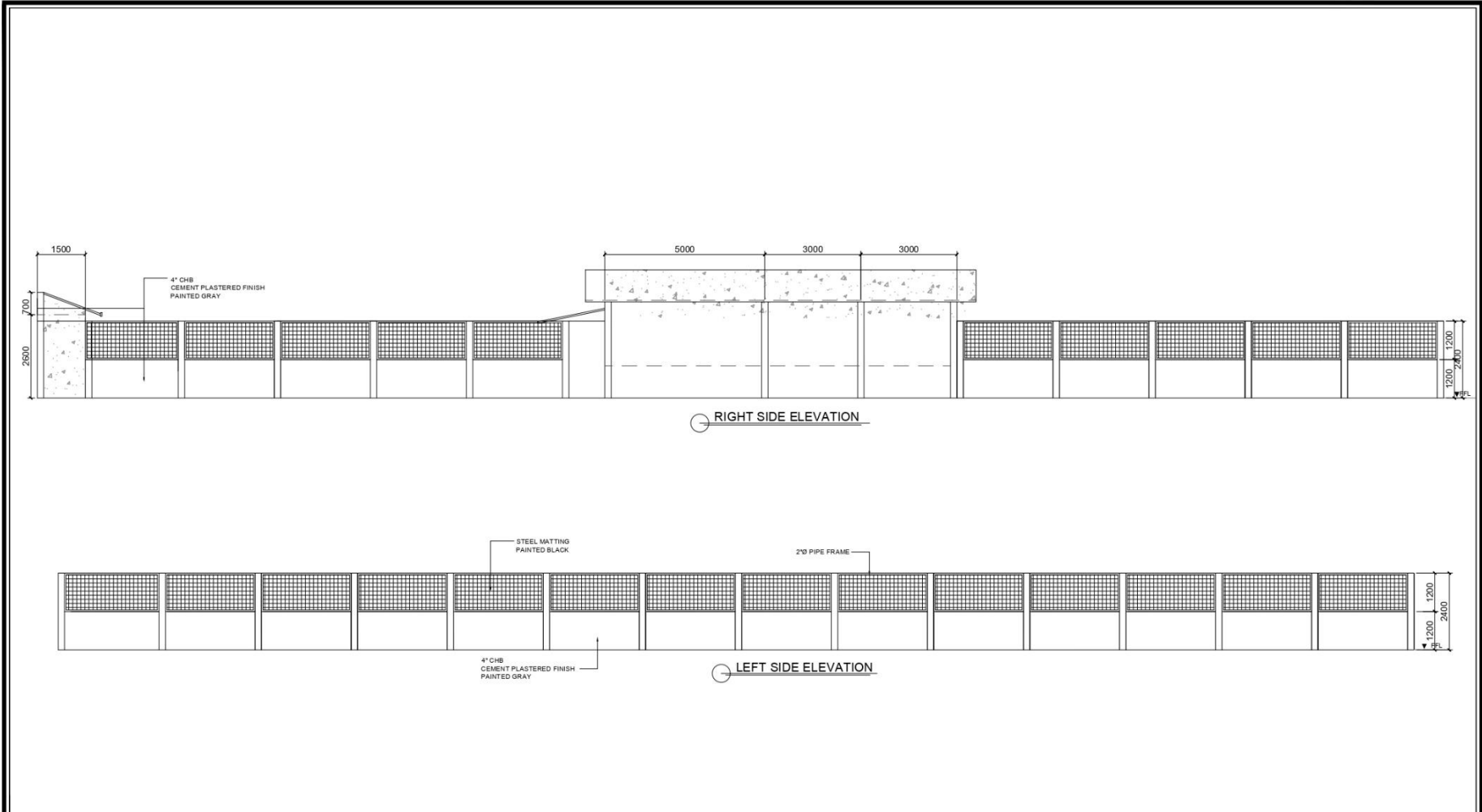

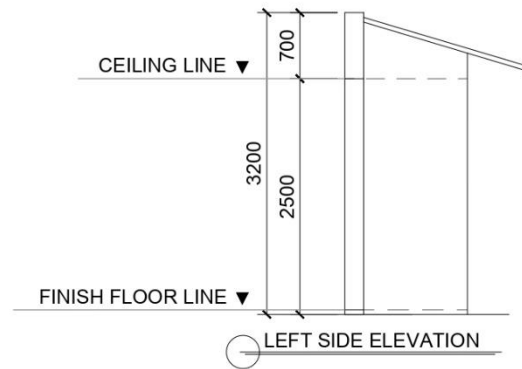
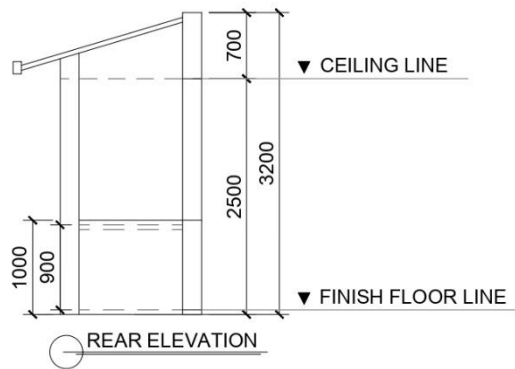
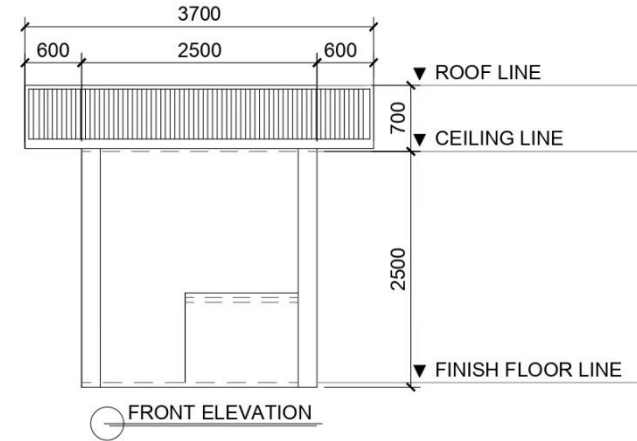
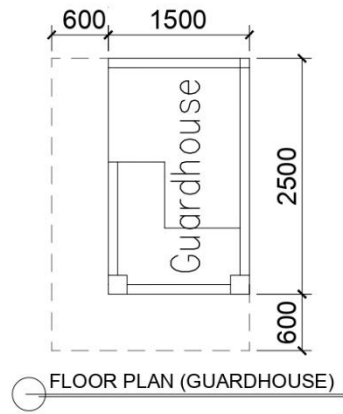

Section VIII. Bill of Quantities

PROJECT : Project Name
 LOCATION : Project Location

B I L L O F Q U A N T I T I E S

Item No.	DESC	UNIT	QTY	MATERIAL COST	AMOUNT	LABOR COST	AMOUNT	TOTAL COST
Div. 1	GENERAL REQUIREMENTS	lot	1					
Div. 2	EARTHWORKS	lot	1					
Div. 3	FORMWORKS	lot	1					
Div. 4	REINFORCING STEEL BARS	lot	1					
Div. 5	CONCRETE	lot	1					
Div. 6	MASONRY	lot	1					
Div. 7	THERMAL AND MOISTURE PROTECTION	lot	1					
Div. 8	METALS	lot	1					

Div. 9	PLUMBING	lot	1					
Div. 10	ELECTRICAL WORKS	lot	1					
Div. 11	AUXILLARY WORKS	lot	1					
Div. 12	MECHANICAL	lot	1					
Div. 13	DOORS AND WINDOWS	lot	1					
Div. 14	FINISHES	lot	1					
Div. 15	SPECIALTIES	lot	1					
Div. 16	SITE DEVELOPMENT	lot	1					
	TOTAL AMOUNT OF THE PROJECT							

*Reference Format of Bill of Quantities

Name of Bidder:	
Name of Duly Authorized Representative:	
Designation	
Signature	
Date:	

Note: A signature box shall be added at the bottom of each page of the Bill of Quantities where the authorized representative of the Bidder shall affix his signature. Failure of the authorized representative to sign each and every page of the Bill of Quantities shall be a cause for rejection of his bid.

Section IX. Checklist of Technical and Financial Documents

I. TECHNICAL COMPONENT ENVELOPE

Class “A” Documents

Legal Documents

- (a) Valid PhilGEPS Registration Certificate (Platinum Membership) (all pages) in accordance with Section 8.5.2 of the IRR;

Technical Documents

- (b) Statement of the prospective bidder of all its ongoing government and private contracts, including contracts awarded but not yet started, if any, whether similar or not similar in nature and complexity to the contract to be bid; **and**
- (c) Statement of the bidder’s Single Largest Completed Contract (SLCC) similar to the contract to be bid, except under conditions provided under the rules; **and**
- (d) Special PCAB License in case of Joint Ventures; **and** registration for the type and cost of the contract to be bid; **and**
- (e) Original copy of Bid Security. If in the form of a Surety Bond, submit also a certification issued by the Insurance Commission;
or
Original copy of Notarized Bid Securing Declaration; **and**
- (f) Project Requirements, which shall include the following:
 - a. Organizational chart for the contract to be bid;
 - b. List of contractor’s key personnel (*e.g.*, Project Manager, Project Engineers, Materials Engineers, and Foremen), to be assigned to the contract to be bid, with their complete qualification and experience data;
 - c. List of contractor’s major equipment units, which are owned, leased, and/or under purchase agreements, supported by proof of ownership or certification of availability of equipment from the equipment lessor/vendor for the duration of the project, as the case may be; **and**
- (g) Original duly signed Omnibus Sworn Statement (OSS); **and** if applicable, Original Notarized Secretary’s Certificate in case of a corporation, partnership, or cooperative; or Original Special Power of Attorney of all members of the joint venture giving full power and authority to its officer to sign the OSS and do acts to represent the Bidder.

Additional Documents in accordance with the Specification (Scope of Work)

- (h) Site Inspection Certificate
- (i) ISO 9001:2015 Certificate
- (j) Preliminary Conceptual Design Plans (please refer to Scope of Work VIII. Submittals and Deliverables)
- (k) Preliminary Detailed Reports
 - a. General Notes and Technical Specifications describing type and quality of materials and equipment to be use, manner of construction and the general conditions under which the project is to be constructed.
 - b. Summary of Works
 - c. Design and Construction Methods
 - d. List of Design and Construction Personnel

- e. Value of Engineering Analysis of Design

Financial Documents

- (l) The prospective bidder's computation of Net Financial Contracting Capacity (NFCC).

Class "B" Documents

- (m) If applicable, duly signed joint venture agreement (JVA) in accordance with RA No. 4566 and its IRR in case the joint venture is already in existence;

or

duly notarized statements from all the potential joint venture partners stating that they will enter into and abide by the provisions of the JVA in the instance that the bid is successful.

Additional Documents in accordance with Annex "G" of RA 9184 Guidelines for the Procurement and Implementation of Contracts for Design and Build Infrastructure Projects

- (n) Relevant statements of all on-going, completed, awarded but not yet started design/design and build related contracts, curriculum vitae of key staff, partners or principal officers;
- (o) Valid licenses issued by the Professional Regulatory Commission (PRC) for design professionals.

II. FINANCIAL COMPONENT ENVELOPE

- (p) Original of duly signed and accomplished Financial Bid Form; **and**

Other documentary requirements under RA No. 9184

- (q) Original of duly signed Bid Prices in the Bill of Quantities; **and**
- (r) Duly accomplished Detailed Estimates Form, including a summary sheet indicating the unit prices of construction materials, labor rates, and equipment rentals used in coming up with the Bid; **and**
- (s) Cash Flow by Quarter.

Additional Documents in accordance with the Specification (Scope of Work)

- (t) Detailed Unit Price Analysis (DUPA) showing sources of data and all calculations made in determining the unit price of each item of work, including profit factor, overhead, contractor's tax, etc.

Section X. Forms

MANDATORY PROVISIONS (FOR INFRA)

Reference fohe following document to be submitted by Bidders shall contain the following mandatory provisions:

Document	Mandatory Provisions
Bid Form	<ul style="list-style-type: none"> i. Bid prices in figures and in words; and ii. The Bid price shall include the cost of all taxes, such as, but not limited to, value added tax, income tax, local taxes, and other fiscal levies and duties which shall be itemized in the bid form and reflected in the price schedule or detailed estimates.
Bid Securing Declaration	<ul style="list-style-type: none"> i. Bidder shall enter into contract with the PE and furnish the required performance security within ten (10) calendar days, from receipt of the Notice of Award; and ii. Bidder accepts that: <ul style="list-style-type: none"> 1. It shall be automatically disqualified from bidding for any procurement contract with any PE for a period of two (2) years upon receipt of the Blacklisting Order; and 2. It will pay the applicable fine provided under the Guidelines on the Use of Bid Securing Declaration, within fifteen (15) days from receipt of the written demand by the PE for the commission of acts resulting to the enforcement of the Bid Securing Declaration under the pertinent provisions of the IRR of RA No. 9184, and its associated issuances.
Omnibus Sworn Statement	<ul style="list-style-type: none"> i. The signatory is the duly authorized representative of the Bidder, and granted full power and authority to do, execute and perform any and all acts necessary to participate, submit the bid, and to sign and execute the ensuing contract accompanied by relevant notarized document; ii. Bidder is not “blacklisted” or barred from bidding by the Government of the Philippines or any of its agencies, offices, corporations, or local government units, including foreign government/foreign or international financing institution whose blacklisting rules have been recognized by the GPPB, by itself or by relation, membership, association, affiliation, or controlling interest with another blacklisted

	<p>person or entity as defined and provided for in the Uniform Guidelines on Blacklisting. [NEW]</p> <ul style="list-style-type: none"> iii. Each of the documents submitted in satisfaction of the bidding requirements is an authentic copy of the original, complete, and all statements and information provided therein are true and correct; iv. Bidder authorizes the HoPE or his/her duly authorized representative/s to verify all the documents submitted; v. Bidder complies with the disclosure provision under Section 47 of RA No. 9184 and its 2016 revised IRR, in relation to other provisions of RA No. 3019; vi. Bidder complies with existing labor laws and standards; vii. Bidder complies with the responsibilities of a prospective or eligible bidder provided in the PBDs; viii. Bidder did not give or pay, directly or indirectly, any commission, amount, fee, or any form of consideration, pecuniary or otherwise, to any person or official, personnel or representative of the government in relation to any Procurement Project or activity; and ix. In case advance payment was made or given, failure to perform or deliver any of the obligations and undertakings in the contract shall be sufficient grounds to constitute criminal liability for Swindling (Estafa) or the commission of fraud with unfaithfulness or abuse of confidence through misappropriating or converting any payment received by a person or entity under an obligation involving the duty to deliver certain goods or services, to the prejudice of the public and the government of the Philippines pursuant to Article 315 of Act No. 3815 s. 1930, as amended, or the Revised Penal Code. [NEW]
Statement of the Bidder of all its ongoing government and private contracts, including contracts awarded but not yet started	<ul style="list-style-type: none"> i. Names of outstanding contracts with other contracting party, i.e., PE or private company allowed by the rules, contract date, period and amount or value;
Statement of the Bidder's SLCC similar to the contract to be bid	<ul style="list-style-type: none"> i. Name of the completed contract with contract date, period and amount, which should correspond to the required percentage of the ABC to be bid. The value is adjusted to the current prices using the Philippine Statistics Authority consumer price indices, when necessary; ii. Definition or description of the similar project or

	major categories of work.
Owner's Certificate of Acceptance or CPES rating accompanying the Statement of the Bidder's SLCC	<ul style="list-style-type: none"> i. For Owner's Certificate of Acceptance: <ul style="list-style-type: none"> 1. Name of project owner that issued the certificate. 2. Name of Contractor/Constructor. 3. Name of Contract; and 4. Contract Duration. ii. For CPES rating, a final rating of at least Satisfactory. For contracts with the private sector an equivalent document shall be submitted.
Bidder's Computation of NFCC or committed Line of Credit (CLC) for Goods	<ul style="list-style-type: none"> i. For NFCC Computation: <ul style="list-style-type: none"> 1. ABC to be bid; 2. Amount or value of bidder's current assets based on Audited Financial Statements (AFS); 3. Amount or value of bidder's current liabilities based on AFS; and 4. Amount or value of all outstanding or uncompleted portions of the projects under ongoing contracts, including awarded contracts yet to be started, coinciding with the contract to be bid. ii. For CLC: <ul style="list-style-type: none"> 1. ABC to be bid; 2. Amount, which should be at least equal to ten percent (10%) of the ABC; and 3. Name of issuing foreign Universal or Commercial Bank, as confirmed or authenticated by a local Universal or Commercial Bank
Joint Venture Agreement (JVA) or Notarized Statements as to forming JV for Goods	<ul style="list-style-type: none"> i. If a JVA is already in existence, the contents shall include the responsibility of each of the JV partners or its contributions to the JV; and ii. The contents of the Notarized Statements from all potential JV partners shall include that: <ul style="list-style-type: none"> a. they will enter into and abide by the provisions of the JVA in the event that the bid is successful; and b. failure to enter into JVA in the event of a contract award shall be a ground for bid disqualification and subsequent forfeiture of the bid security.

PhilGEPS Registration Certificate (Platinum Membership)

Bidders are reminded in accordance with Government Procurement Policy Board (GPPB) Resolution No. 15-2021 dated 14 October 2021, “Lifting the Suspension on the Implementation of the Mandatory Submission of PhilGEPS Certificate of Platinum Registration and Membership in Competitive Bidding and Limited Source Bidding; Amending Sections 8.5.2, 23.1(a)(ii), 23.3, 24.1(a)(ii), 24.4.3, 34.3 And 54.6 Of The 2016 Revised IRR of RA No. 9184, items iv(g)(l) and v(d)(l)(b) as well as Appendix “A” of Annex “H” Thereof, Items 4 And 6 of the Guidelines for the use of the Government of the Philippines - Official Merchants Registry, and Item 1 of Sections viii and ix of the 6th Edition of the Philippine Bidding Documents for Goods and Infrastructure Projects” a new Platinum Certificate reflecting the following caveat shall be required from all Platinum Merchants (Bidders) starting 01 January 2022 when participating in Public Bidding and Limited Source Bidding:

That for the purpose of updating the PhilGEPS Certificate of Platinum Registration and Membership, all Class “A” Eligibility Documents covered by Section 8.5.2 of the 2016 revised IRR of RA 9184 supporting the veracity, authenticity and validity of the Certificate shall remain current and updated, and that **failure by the prospective bidder to update its PhilGEPS Certificate of Platinum Registration and Membership with the current and updated Class “A” Eligibility Documents covered by Section 8.5.2 of the 2016 revised IRR of RA 9184 shall result in the automatic suspension of the validity of its Certificate of Platinum Registration and Membership until such time that all of the expired Class “A” Eligibility Documents has been updated;** and

To reflect that through the submission of said Certificate, the Bidder certifies:

- a. the authenticity, genuineness, validity, and completeness of the copy of the original eligibility documents submitted.
- b. the veracity of the statements and information contained therein;
- c. that the Certificate is neither a guaranty that the named registrant will be declared eligible without first being determined to be such for that particular bidding nor is it evidence that the Bidder has passed the post qualification stage; and
- d. that any finding of concealment, falsification, or misrepresentation on the part of the Bidder of any of the eligibility documents submitted or the contents thereof shall be a ground for disqualification from further participation in the bidding process, without prejudice to the imposition of appropriate administrative, civil and criminal penalty in accordance with the laws

Thus, all Platinum Merchants (Bidder) shall be required starting 01 January 2022 to update/renew, re-download and reprint their Platinum Certificate to reflect the foregoing caveat. All Procuring Entities shall require the new Platinum Certificate and apply concomitant amendments in accordance with GPPB Resolution No. 15-2021

As per PhilGEPS Advisory No. 2022-007, Merchant can update their valid Platinum Documents at any time by logging into their MGEPS account. There is no additional fee or approval from the PhilGEPS Admin.

**REVISED PhilGEPS CERTIFICATE OF PLATINUM REGISTRATION AND MEMBERSHIP
(First Page Only)**

Republic of the Philippines
Department of Budget and Management
PROCUREMENT SERVICE

**CERTIFICATE OF PHILGEPS REGISTRATION
(Platinum Membership)**

THIS IS TO CERTIFY THAT

(NAME OF BIDDER)
Address

is registered in the Philippine Government Electronic Procurement System (PhilGEPS) on (date of registration) pursuant to Section 8.5.2 of the Revised Implementing Rules and Regulations of Republic Act No. 9184, otherwise known as the Government Procurement Reform Act.

This further certifies that (name of the prospective bidder) has submitted the required eligibility documents in the PhilGEPS Supplier Registry as listed in Annex A which document is attached hereto and made an integral part hereof.

For the purpose of updating this Certificate, all Class "A" eligibility documents covered by Section 8.5.2 of the Revised Implementing Rules and Regulations of Republic Act No. 9184 supporting the veracity, authenticity and validity of this Certificate shall remain current and updated. The failure by the prospective bidder to update this Certificate with the current and updated Class "A" eligibility documents shall result in the automatic suspension of its validity until such time that all of the expired Class "A" eligibility documents has been updated.

By submitting this Certificate, the Bidder certifies:

- 1. the authenticity, genuineness, validity, and completeness of the copy of the original eligibility documents submitted;**
- 2. the veracity of the statements and information contained therein;**
- 3. that the Certificate is not a warranty that the named registrant will be declared eligible without first being determined to be such for that particular bidding, nor is it evidence that the Bidder has passed the post-qualification stage; and**
- 4. that any finding of concealment, falsification, or misrepresentation of any of the eligibility documents submitted, or the contents thereof shall be a ground for disqualification from further participation in the bidding process, without prejudice to the imposition of appropriate administrative, civil and criminal penalty in accordance with the laws.**

This Certificate is valid until (date of expiration).

Issued this (date) day of (month), year.

This is a system-generated certificate. No signature is required.

Documentary Stamp Tax Paid 30.00
Certificate Reference No:

(QR Code)

Page 1 of 3

Bid Securing Declaration Form

[shall be submitted with the Bid if bidder opts to provide this form of bid security]

REPUBLIC OF THE PHILIPPINES)
CITY OF _____) S.S.

BID SECURING DECLARATION **Project Identification No.: *[Insert number]***

To: *[Insert name and address of the Procuring Entity]*

I/We, the undersigned, declare that:

1. I/We understand that, according to your conditions, bids must be supported by a Bid Security, which may be in the form of a Bid Securing Declaration.
2. I/We accept that: (a) I/we will be automatically disqualified from bidding for any procurement contract with any procuring entity for a period of two (2) years upon receipt of your Blacklisting Order; and, (b) I/we will pay the applicable fine provided under Section 6 of the Guidelines on the Use of Bid Securing Declaration, within fifteen (15) days from receipt of the written demand by the procuring entity for the commission of acts resulting to the enforcement of the bid securing declaration under Sections 23.1(b), 34.2, 40.1 and 69.1, except 69.1(f), of the IRR of RA No. 9184; without prejudice to other legal action the government may undertake.
3. I/We understand that this Bid Securing Declaration shall cease to be valid on the following circumstances:
 - a. Upon expiration of the bid validity period, or any extension thereof pursuant to your request;
 - b. I am/we are declared ineligible or post-disqualified upon receipt of your notice to such effect, and (i) I/we failed to timely file a request for reconsideration or (ii) I/we filed a waiver to avail of said right; and
 - c. I am/we are declared the bidder with the Lowest Calculated Responsive Bid, and I/we have furnished the performance security and signed the Contract.

IN WITNESS WHEREOF, I/We have hereunto set my/our hand/s this ____ day of *[month]* *[year]* at *[place of execution]*.

[Insert NAME OF BIDDER OR ITS AUTHORIZED REPRESENTATIVE]

[Insert signatory's legal capacity]

Affiant

[Jurat]

[Format shall be based on the latest Rules on Notarial Practice]

Omnibus Sworn Statement (Revised)
[shall be submitted with the Bid]

REPUBLIC OF THE PHILIPPINES)
CITY/MUNICIPALITY OF _____) S.S.

AFFIDAVIT

I, [Name of Affiant], of legal age, [Civil Status], [Nationality], and residing at [Address of Affiant], after having been duly sworn in accordance with law, do hereby depose and state that:

1. *[Select one, delete the other:]*

[If a sole proprietorship:] I am the sole proprietor or authorized representative of [Name of Bidder] with office address at [address of Bidder];

[If a partnership, corporation, cooperative, or joint venture:] I am the duly authorized and designated representative of [Name of Bidder] with office address at [address of Bidder];

2. *[Select one, delete the other:]*

[If a sole proprietorship:] As the owner and sole proprietor, or authorized representative of [Name of Bidder], I have full power and authority to do, execute and perform any and all acts necessary to participate, submit the bid, and to sign and execute the ensuing contract for [Name of the Project] of the [Name of the Procuring Entity], as shown in the attached duly notarized Special Power of Attorney;

[If a partnership, corporation, cooperative, or joint venture:] I am granted full power and authority to do, execute and perform any and all acts necessary to participate, submit the bid, and to sign and execute the ensuing contract for [Name of the Project] of the [Name of the Procuring Entity], as shown in the attached [state title of attached document showing proof of authorization (e.g., duly notarized Secretary's Certificate, Board/Partnership Resolution, or Special Power of Attorney, whichever is applicable)];

3. [Name of Bidder] is not "blacklisted" or barred from bidding by the Government of the Philippines or any of its agencies, offices, corporations, or Local Government Units, foreign government/foreign or international financing institution whose blacklisting rules have been recognized by the Government Procurement Policy Board, **by itself or by relation, membership, association, affiliation, or controlling interest with another blacklisted person or entity as defined and provided for in the Uniform Guidelines on Blacklisting;**

4. Each of the documents submitted in satisfaction of the bidding requirements is an authentic copy of the original, complete, and all statements and information provided therein are true and correct;

5. [Name of Bidder] is authorizing the Head of the Procuring Entity or its duly authorized representative(s) to verify all the documents submitted;

6. *[Select one, delete the rest:]*

[If a sole proprietorship:] The owner or sole proprietor is not related to the Head of the Procuring Entity, members of the Bids and Awards Committee (BAC), the Technical Working Group, and

the BAC Secretariat, the head of the Project Management Office or the end-user unit, and the project consultants by consanguinity or affinity up to the third civil degree;

[If a partnership or cooperative:] None of the officers and members of *[Name of Bidder]* is related to the Head of the Procuring Entity, members of the Bids and Awards Committee (BAC), the Technical Working Group, and the BAC Secretariat, the head of the Project Management Office or the end-user unit, and the project consultants by consanguinity or affinity up to the third civil degree;

[If a corporation or joint venture:] None of the officers, directors, and controlling stockholders of *[Name of Bidder]* is related to the Head of the Procuring Entity, members of the Bids and Awards Committee (BAC), the Technical Working Group, and the BAC Secretariat, the head of the Project Management Office or the end-user unit, and the project consultants by consanguinity or affinity up to the third civil degree;

7. *[Name of Bidder]* complies with existing labor laws and standards; and
8. *[Name of Bidder]* is aware of and has undertaken the responsibilities as a Bidder in compliance with the Philippine Bidding Documents, which includes:
 - a. Carefully examining all of the Bidding Documents;
 - b. Acknowledging all conditions, local or otherwise, affecting the implementation of the Contract;
 - c. Making an estimate of the facilities available and needed for the contract to be bid, if any; and
 - d. Inquiring or securing Supplemental/Bid Bulletin(s) issued for the *[Name of the Project]*.
9. *[Name of Bidder]* did not give or pay directly or indirectly, any commission, amount, fee, or any form of consideration, pecuniary or otherwise, to any person or official, personnel or representative of the government in relation to any procurement project or activity.
10. **In case advance payment was made or given, failure to perform or deliver any of the obligations and undertakings in the contract shall be sufficient grounds to constitute criminal liability for Swindling (Estafa) or the commission of fraud with unfaithfulness or abuse of confidence through misappropriating or converting any payment received by a person or entity under an obligation involving the duty to deliver certain goods or services, to the prejudice of the public and the government of the Philippines pursuant to Article 315 of Act No. 3815 s. 1930, as amended, or the Revised Penal Code.**

IN WITNESS WHEREOF, I have hereunto set my hand this ___ day of ___, 20__ at _____, Philippines.

[Insert NAME OF BIDDER OR ITS AUTHORIZED REPRESENTATIVE]

[Insert signatory's legal capacity]

Affiant

[Jurat]

[Format shall be based on the latest Rules on Notarial Practice]

[Letterhead of the Bidder]

***Statement of ALL ongoing government and private contracts
(Including contracts awarded but not yet started)***

NAME OF THE PROJECT :
 BIDDER's COMPANY NAME :
 COMPANY ADDRESS :

Item No.	a) Name of Contract b) Contract Duration	Contract Date		Owner's Name and Address/ Party Contracting with Bidder	% of Participation	a) Amount of Contract b) Value of Outstanding Contracts	Date of Delivery
		Start mm/dd/yy	Completion mm/dd/yy				
GOVERNMENT							
	a) b)					a) b)	
PRIVATE							
	a) b)					a) b)	
						Total Amount:	

Instructions:

1. Indicate the correct and complete information required for each contract.
2. In case there are no ongoing contracts, put N/A or None.

Submitted by: _____
 (Printed Name and Signature)

Designation: _____

Date: _____

[Letterhead of the Bidder]

Statement of the bidder's Single Largest Completed Contract (SLCC)

NAME OF THE PROJECT :

BIDDER's COMPANY NAME :

COMPANY ADDRESS :

Name of Contract Date of Contract Contract Duration	Owner's Name and Address/ Party Contracting with Bidder	Definition or description of the similar project or major categories of work	Amount of Completed Contract	Date of Delivery

Instructions:

1. Indicate the correct and complete information required of the contract
2. **The SLCC shall be supported by an Owner's Certificate of Final Acceptance issued by the project owner other than the contractor or a final rating of at least Satisfactory in the Constructors Performance Evaluation System (CPES). In case of contracts with the private sector, an equivalent document shall be submitted.**

Submitted by : _____
(Printed Name and Signature)

Designation : _____

Date : _____

Bid Form for the Procurement of Infrastructure Projects

[shall be submitted with the Bid]

BID FORM

Date : _____
Project Identification No. : _____

To: *[name and address of Procuring Entity]*

Having examined the Philippine Bidding Documents (PBDs) including the Supplemental or Bid Bulletin Numbers *[insert numbers]*, the receipt of which is hereby duly acknowledged, we, the undersigned, declare that:

- a. We have no reservation to the PBDs, including the Supplemental or Bid Bulletins, for the Procurement Project: *[insert name of contract]*;
- b. We offer to execute the Works for this Contract in accordance with the PBDs;
- c. The total price of our Bid in words and figures, excluding any discounts offered below is: *[insert information]*;
- d. The discounts offered and the methodology for their application are: *[insert information]*;
- e. The total bid price includes the cost of all taxes, such as, but not limited to: *[specify the applicable taxes, e.g. (i) value added tax (VAT), (ii) income tax, (iii) local taxes, and (iv) other fiscal levies and duties]*, which are itemized herein and reflected in the detailed estimates,
- f. Our Bid shall be valid within the a period stated in the PBDs, and it shall remain binding upon us at any time before the expiration of that period;
- g. If our Bid is accepted, we commit to obtain a Performance Security in the amount of *[insert percentage amount]* percent of the Contract Price for the due performance of the Contract, or a Performance Securing Declaration in lieu of the the allowable forms of Performance Security, subject to the terms and conditions of issued GPPB guidelines for this purpose;
- h. We are not participating, as Bidders, in more than one Bid in this bidding process, other than alternative offers in accordance with the Bidding Documents;
- i. We understand that this Bid, together with your written acceptance thereof included in your notification of award, shall constitute a binding contract between us, until a formal Contract is prepared and executed; and
- j. We understand that you are not bound to accept the Lowest Calculated Bid or any other Bid that you may receive.
- k. We likewise certify/confirm that the undersigned, is the duly authorized representative of the bidder, and granted full power and authority to do, execute and perform any and all acts necessary to participate, submit the bid, and to sign

and execute the ensuing contract for the [Name of Project] of the [Name of the Procuring Entity].

- I. We acknowledge that failure to sign each and every page of this Bid Form, including the Bill of Quantities, shall be a ground for the rejection of our bid.

Name: _____

Legal Capacity: _____

Signature: _____

Duly authorized to sign the Bid for and behalf of: _____

Date: _____

